

ASSEMBLY INSTRUCTIONS



DUAL POLARITY V-QUAD BEAM

10 OR 11 METER

VQ2-QUAD

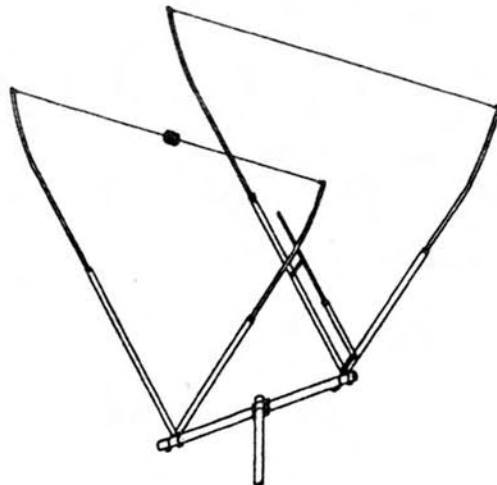

www.macoantennas.net

(815) 244-3500

MACo Antennas, A Division of Charles Electronics, LLC
302 S. East Street, Mt. Carroll, IL 61053

MACO VQ2 QUAD

PACKING LIST

<u>PART</u>	<u>QTY</u>	<u>OD</u>	<u>SIZE</u>	<u>LENGTH</u>	<u>DESCRIPTION</u>	<u>CHECKLIST</u>
T12P	4	1/2"	.050"	72"	ALUM. TUBING FLATTENED W/HOLE	_____
T13P	4	5/8"	.050"	72"	ALUM. TUBING SLOTTED ONE END	_____
T28	1	1 1/2"	.050"	72"	ALUM. TUBING	_____
T50P	2	1 3/8"	.050	4"	ALUM. TUBING	_____
P01P	1		1/4" x 5"	5"	PLATE	_____
W01P	1		7/14	34"	COPPER WIRE	_____
G06P	1			30"	GAMMA MATCH (LONG ONE)	_____
S42	1				FEMALE COAX CONNECTOR W/MTG NUT	_____
Z09P	2			3"	GAMMA STRAPS W/COAX CONNECTOR	_____

HARDWARE BAG #1

U02	8		1 1/2"		PLATED U-BOLTS	_____
S02	8		1 1/2"		PLATED SADDLES	_____
N03	16		5/16"		LOCK NUTS	_____

HARDWARE BAG #2

BE1P	4				BOOM TO ELEMENT MOUNTS	_____
W58P	4		5/8"		EXTRUDED ALUMINUM CLAMPS	_____
N11	13		10-24"		SQUARE NUTS	_____
S30	4		#12	1"	SHEET METAL SCREWS	_____
S21	12		10-24"	1/2"	MACHINE SCREWS	_____
N26	4		#10		FLAT WASHERS	_____
N12	4		#10		LOCK WASHERS	_____
F01P	1		3/4"		COIL FORM	_____
PL10	1		1.187-32		PLASTIC CAP-BLACK W/HOLE	_____
Z01P	2		1/2"	3"	GAMMA STRAPS	_____
P11	1				BLACK PLASTIC CAP W/HOLE	_____
	1				TIP SHEET	_____
	1				WARRANTY SHEET	_____
	1				SET OF INSTRUCTIONS	_____

WHEN ORDERING PARTS, ALWAYS GIVE PART NUMBER AND DESCRIPTION.

Please note: In an effort to keep the price on Maco Antennas down, we have decided not to clean up all the burrs and rough edges on the parts. We recommend that you deburr and clean up each part with files, sandpaper, etc. so that they go together easily. We are aware this needs to be done but have elected not to do it to save you the money we would have to add to the price of the kit for this service.

MACO VQ2 QUAD

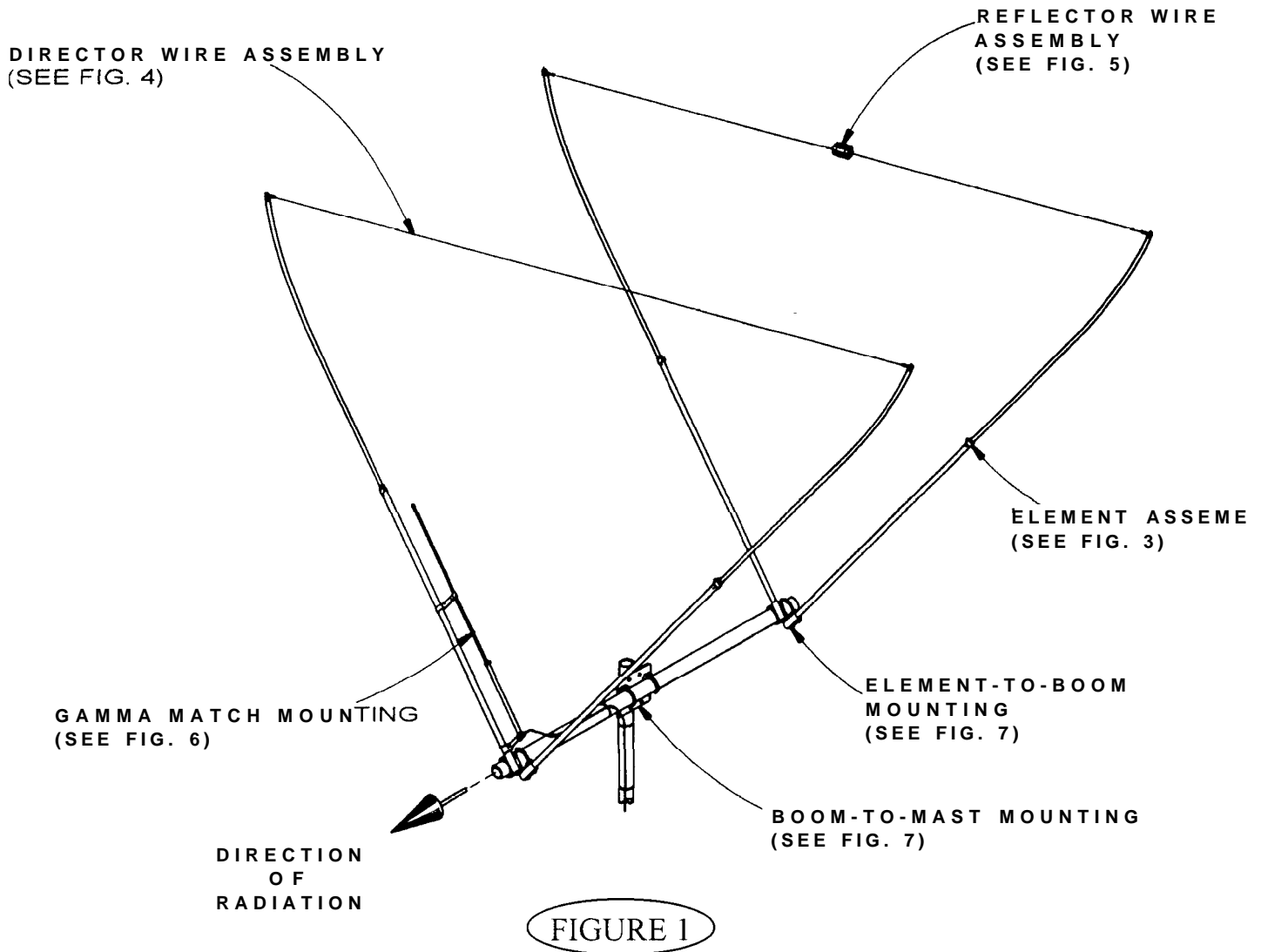
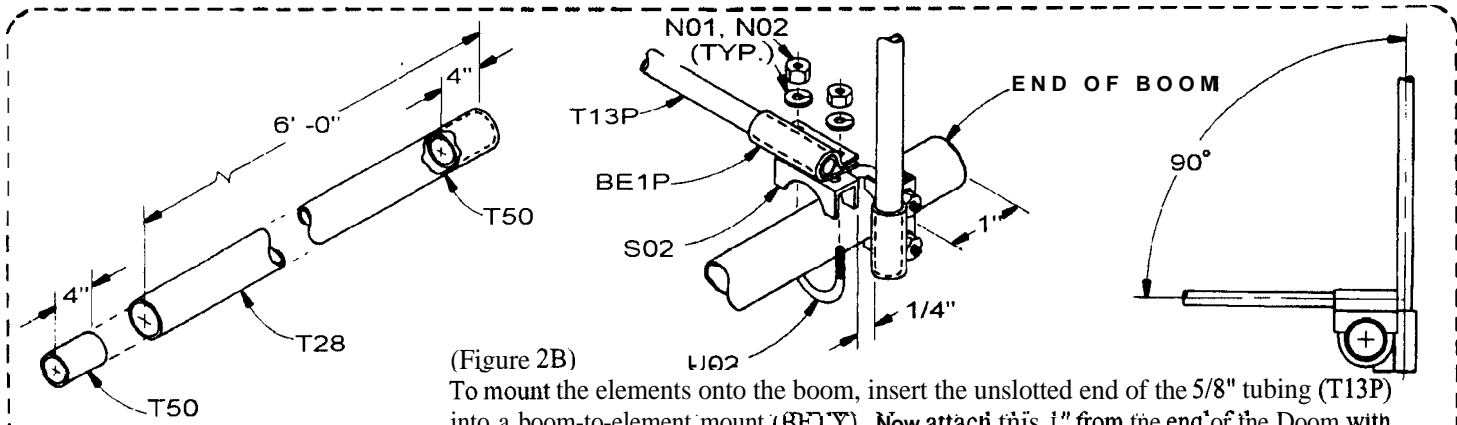

FIGURE 1 GENERAL ASSEMBLY INSTRUCTIONS

This figure depicts an overall view of what the antenna should look like upon completion of assembly. Refer to Figures 2 through 7 for specific assembly details. All hardware should be coated with a silicon rubber sealant or similar compound to insure that wind vibration does not cause it to work loose.



(Figure 2A)

Slide a 4" boom reinforcer (T50) into each end of the boom (T28) as shown.

(Figure 2B)

To mount the elements onto the boom, insert the unslotted end of the 5/8" tubing (T13P) into a boom-to-element mount (BE1P). Now attach this 1" from the end of the boom with a U-bolt, saddle, and hardware as shown. Tighten the U-bolt so as to crimp the boom into an oval shape. This will prevent the element from twisting. Next, fasten a second length of 5/8" tubing to the boom in the same manner, 1/4" in from, and at a 90 degree angle to the first element mount. Tighten as before.

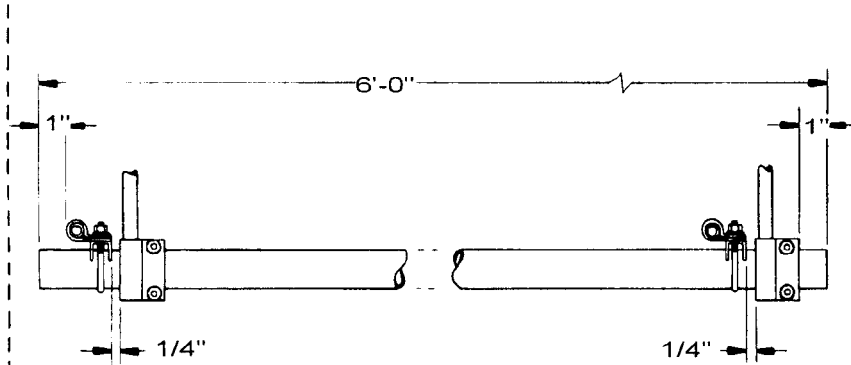

(Figure 2C)

Repeat step 2B on the other end of the boom with the remaining lengths of 5/8" tubing. Be sure the elements are lined up with the ones on the opposite end of the boom and at a 90 degrees angle. Spacing on each end of the boom should be shown as above.

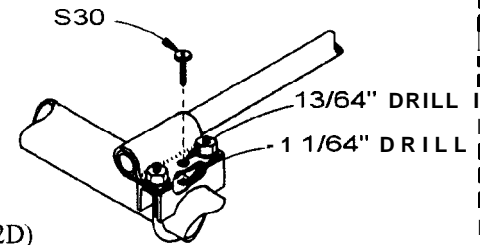

(Figure 2D)

If you live in a high wind area you may further insure that your elements will not twist around the boom. Drill a 13/64" dia. hole thru the center of the element mount (BE1P) & saddle (S02). Using these holes as a guide, drill a 1 1/64" dia. hole thru one side of the boom and install the #12 x 1" sheet metal screw (S30). In areas with normal wind conditions this will not be necessary.

ELEMENT-TO-BOOM MOUNTING

FIGURE 2

Please read the Assembly and Troubleshooting Tips at the end of this instruction booklet before assembling elements.

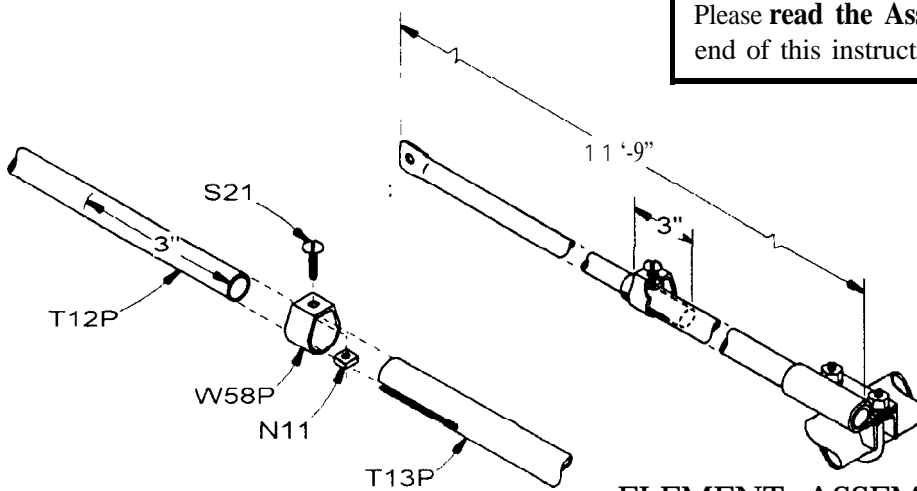

ELEMENT ASSEMBLY

FIGURE 3

Take the (4) lengths of 1/2" tubing (T12P) and mark each one 3" from the unflattened end. Using a W58P clamp and hardware shown, insert the 1/2" tubing into the slotted end of the 5/8" tubing to the mark and tighten clamps. The overall length of each element should be 11' 9".

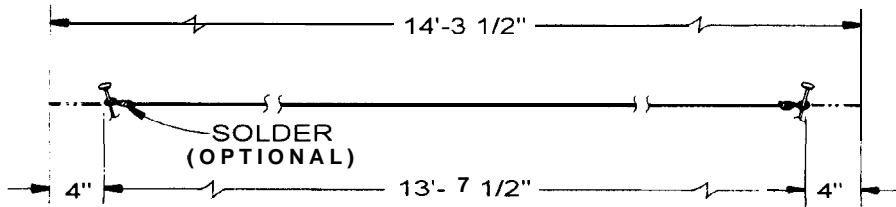

(Figure 4A)

From the 34 ft. roll of copper wire (W01P), measure and cut a length of 14' 3 1/2". Starting 4" from one end, wrap the wire around a nail or any suitable anchor and twist to form a loop as shown. Making sure that there are no kinks, pull the wire tight and measure to a length of 13' 7 1/2". This should allow you 4" to form a loop and twist in the same manner as the opposite end. Check to make sure that your overall length is 13' 7 1/2". If you desire, in order to insure a stronger and more permanent connection, you may solder the wire twists.

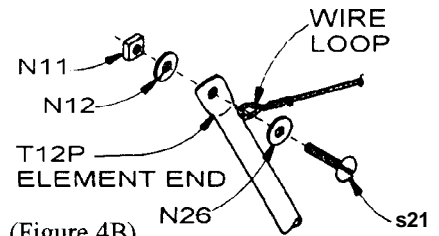

(Figure 4B)

Attach the wire between the element ends on the director end of the boom using #10 hardware as shown. It is normal for the elements to bow towards each other. This will cause a spring action and keep any slack out of the wire.

DIRECT WIRE ASSEMBLY

FIGURE 4

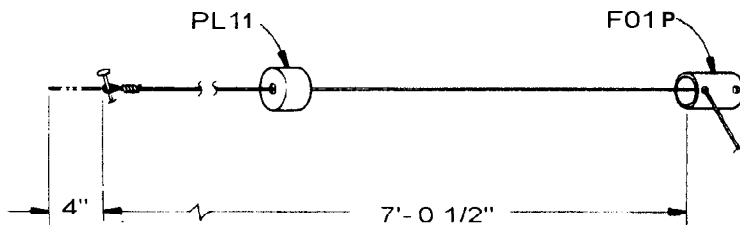

(Figure 5A)

Using the remaining copper wire, start 4" from one end and wrap it around a nail or suitable anchor and twist to form a loop. Next string the loose end of the wire thru the hole in the smaller of the two plastic caps (PL11). Now string the wire thru one of the holes in the coilform (FO1P) from inside to out as shown and slid the coilform over the wire to bring its front edge to a distance of 7' 1/2" from the loop end.

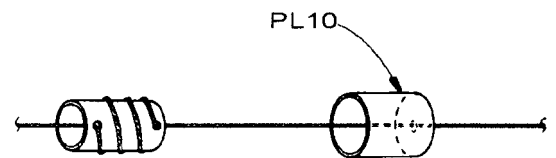

(Figure 5B)

Wind the wire 3 turns around the coilform, maintaining equal spacing between the turns and keeping the coilform in its same position on the wire. String the wire thru the hole in the other end of the coilform. Next string the loose end of the wire thru the hole in the larger plastic cap (PL10).

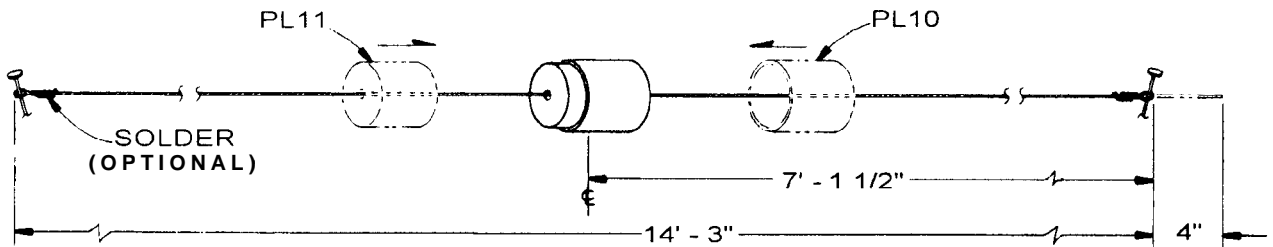

(Figure 5C)

Making sure there are no kinks, pull the wire tight and measure 14' 3" from the loop end of the wire. Allowing 4" for wrapping, cut off any excess and form a loop in the same manner as the opposite end. Now push the small plastic cap over one end of the coilform is in the center of the wire, and that the overall length is 14' 3". Solder your wire twists if desired. Now attach the wire & coil assembly between the element ends on the reflector end of the boom using the #10 hardware. (Refer to Fig. 4B)

REFLECTOR WIRE ASSEMBLY

FIGURE 5

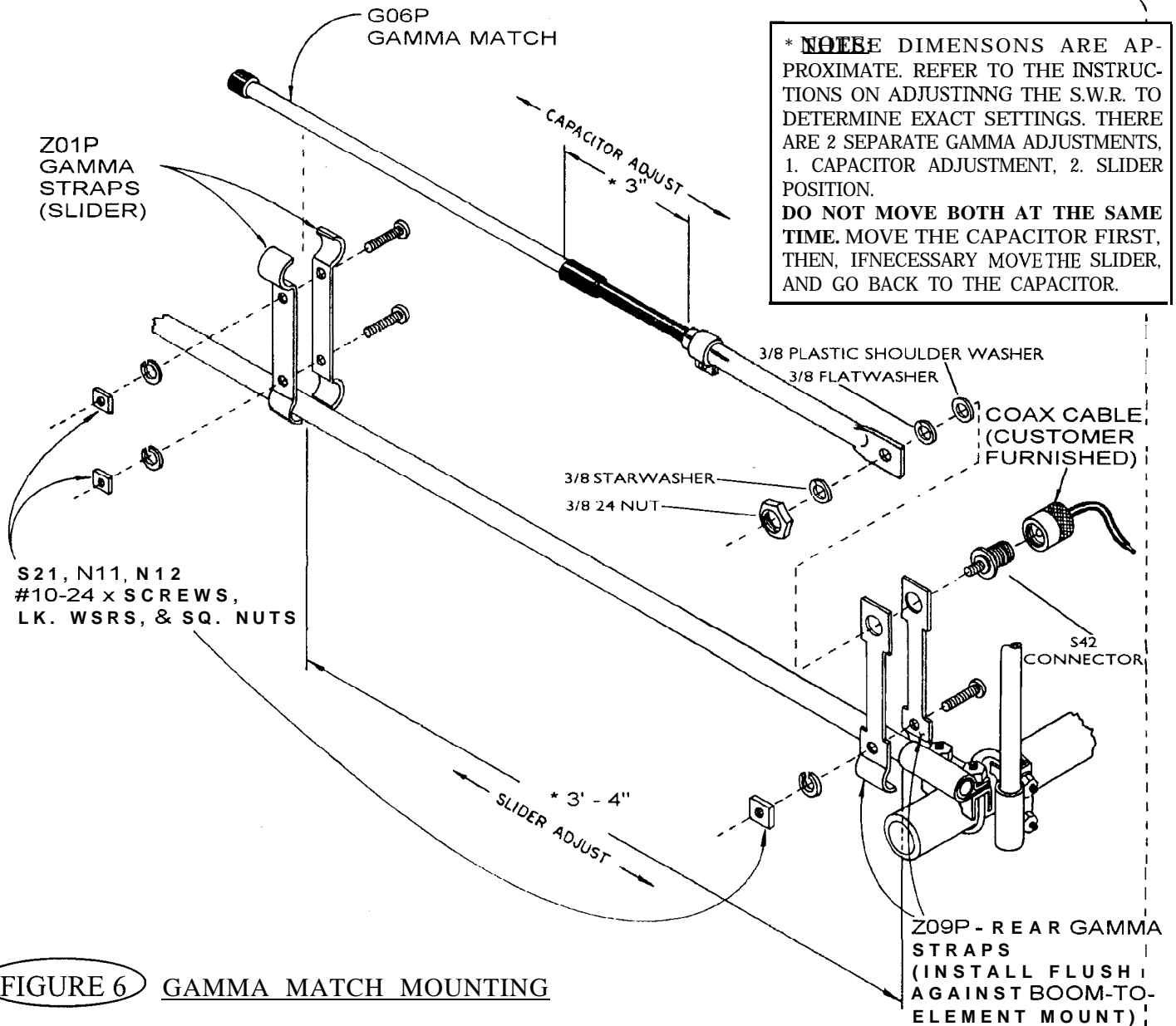

FIGURE 6 GAMMA MATCH MOUNTING

Attach the Gamma Match (G06P) to the driven element on the director end of the boom (ref. Fig. 1) using the Gamma Straps (Z01P, Z09P) and attaching hardware as shown. Attach your coaxial cable to the connector (S42) and dress along boom and down mast.

ADJUSTING STANDING WAVE RATIO

The dimensions given are approximate and should be used as a starting point.*

The Gamma Match has 2 adjustments. First is the capacitor adjustment and second is the slider adjustment. Connect a S.W.R. bridge between your transmitter and the antenna and check the S.W.R. If adjustment is required loosen the clamp on the gammamatch and the screws holding the slider (Gamma Straps Z01P). Next move the capacitor adjustment first in one direction, then the other until a minimum S.W.R. reading is obtained. If S.W.R. is not satisfactory, move the slider out 2" towards the boom. Now readjust the capacitor for a minimum S.W.R. You should now be able to determine which direction to move the slider. Repeat the above procedure, moving the slider in smaller increments until a satisfactory S.W.R. reading is obtained. Tighten all hardware. Disconnect the S.W.R. bridge and reconnect your coaxial cable.

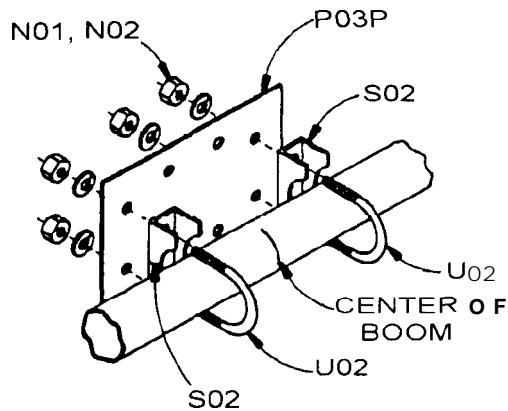

(Figure 7A)
Mark the center of the boom and attach the boom-to-mast plate (P03P) centered on the mark with 1 1/2" U-bolts, saddles and hardware as shown.

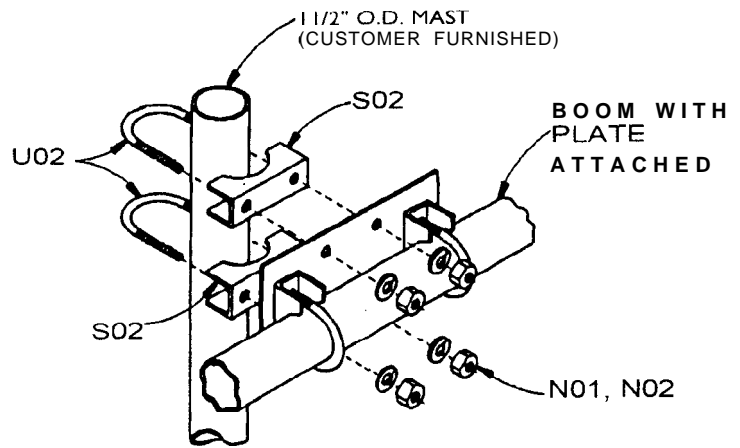

(Figure 7B)
this antenna is designed for mounting on a 1 1/2" O.D. heavy duty mast. Attach using 1 1/2" U-bolts, saddles and hardware as shown.

BOOM-TO-MAST MOUNTING

FIGURE 7

The VQ2-Quad offers CBER's the advantages of both horizontal and vertical polarization with only one coax. feed line. The "V" configuration gives outstanding gain and pin point rejection. Experienced CBER's know how annoying fading due to polarization loss can be. With the dual polarity of the VQ2-Quad, signal fading is reduced as much as 20 Db. Both horizontal and vertical polarization is achieved through the VQ2-Quad loop configuration. Low loss impedance matching Gamma Match assures low S.W.R. for maximum power transfer. A pretuned reflector resonating coil assures max. F/B ratio.

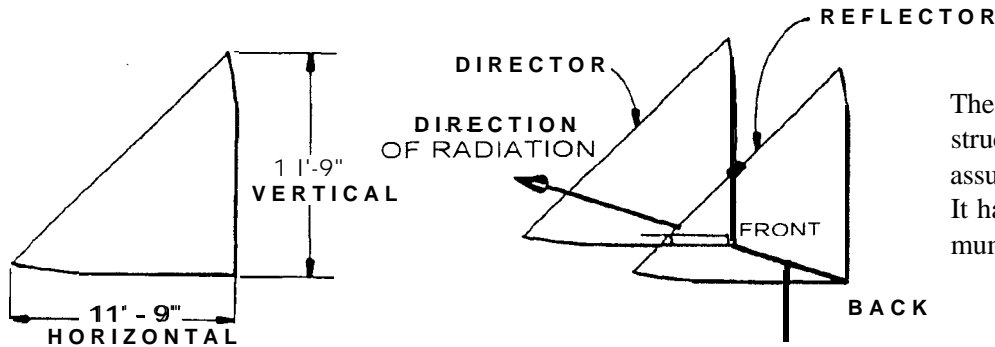

For both horizontal and vertical polarization, mount in configuration above.

The VQ2-Quad's rugged mechanical structure of top grade aluminum tubing assures long lasting dependable service. It handles up to 2000 watts with maximum power transfer.

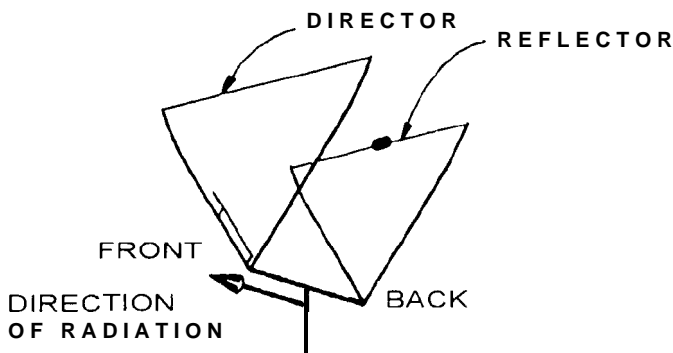

For horizontal polarization, mount as shown here in configuration above.

Mechanical Specifications:

- Boom Length 6' 0"
- Element Length 11' 9"
- Accepts masts up to . . . 1.5"
- Wind survival 100 MPH
- Net Weight 7.4 lbs.

Electrical Specifications:

- Gain 10.5 Db.
- F/B Ratio 25 Db.
- Side Rejection 40 Db.
- S.W.R. 1.2 : 1
- Impedance 50 Ohms
- Polarity Vertical & Horizontal

10 METER ASSEMBLY INSTRUCTIONS

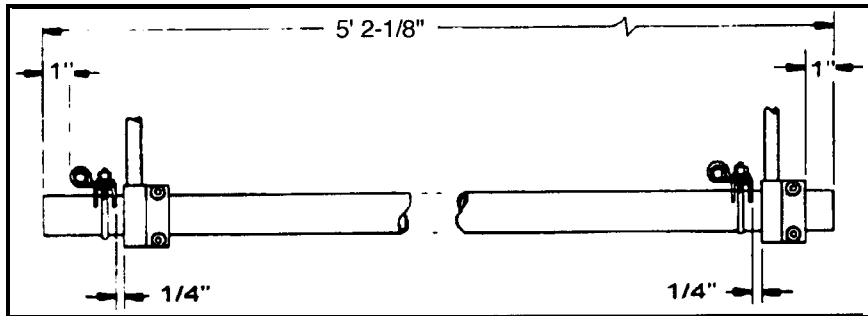

(Figure 2C)

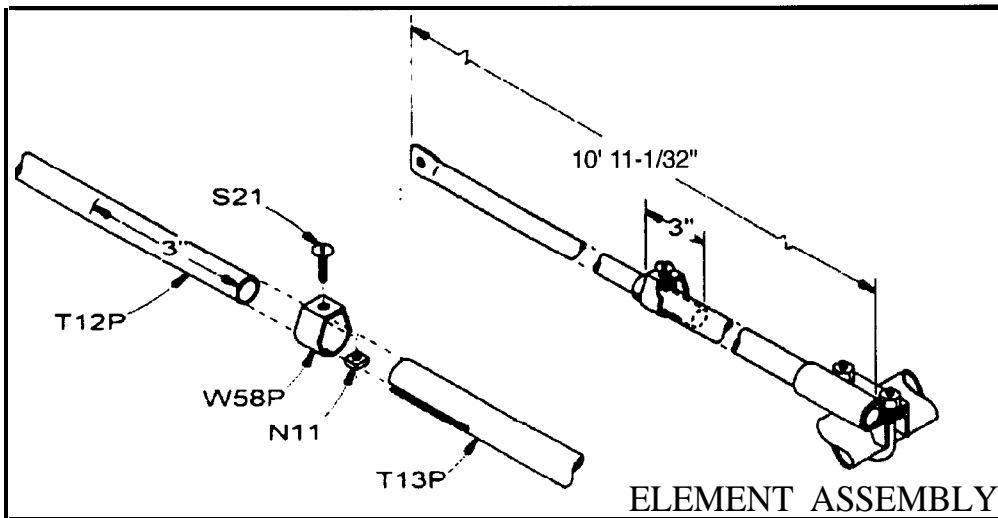

(Figure 3)

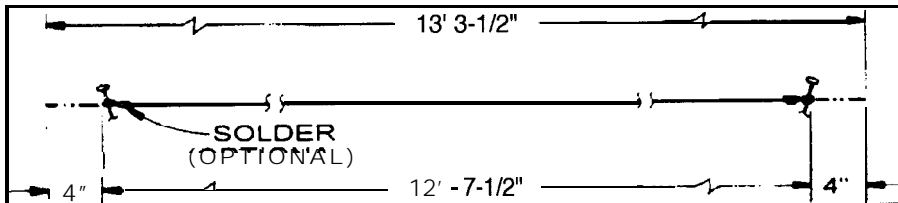

(Figure 4A)

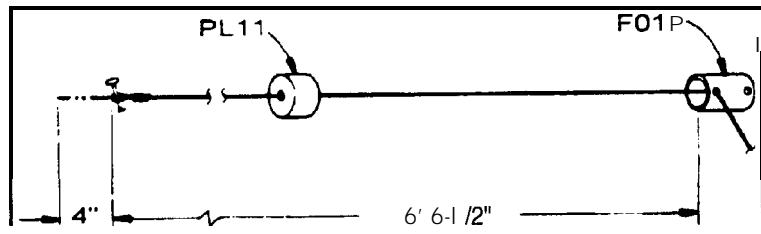

(Figure 5A)

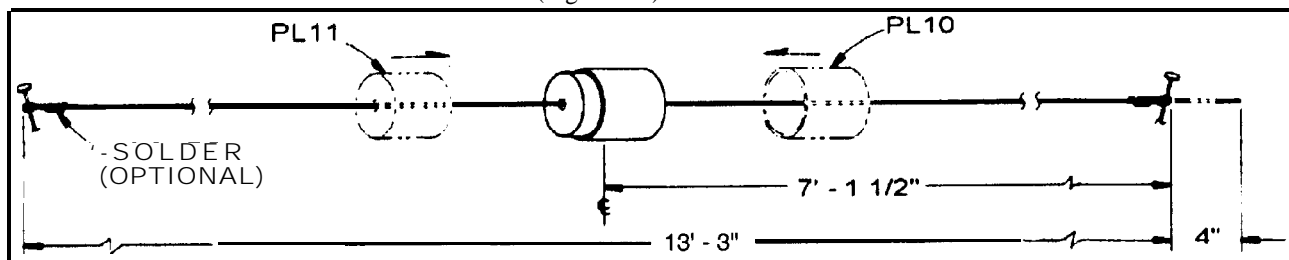

(Figure 5C)



Caution:

**TAKE CARE TO AVOID ANY CONTACT WITH
OVERHEAD POWER LINES WHEN RAISING,
INSTALLING, OR REPAIRING YOUR
ANTENNA, TOWER, OR ROTOR.**

DEATH WILL OCCUR!

Installing and rigging towers, masts and antennas require specialized skills and experience. Information supplied by MACo assumes that all products will be installed by personnel having these skills and have installed similar products before. No one should attempt to install towers or masts without these knowledgeable skills.

MACo assumes no liability if faulty or dangerous installation practices are used. There are available, trained and experienced personnel to assist in installation, maintenance, or disassembly. Contact your local installer if consultation or assistance is required.

All tower and antenna installations should be thoroughly inspected at least twice a year by qualified, experienced, and trained personnel to insure proper performance and safety standards.

Electrical Warning

An additional warning precaution is given to be careful of surrounding high voltage power wires and other electrical hazards during installation of your tower, rotor, or antenna.

Do not erect a tower, rotor, or antenna during an electrical storm, rainstorm, or when lightning is a possibility.

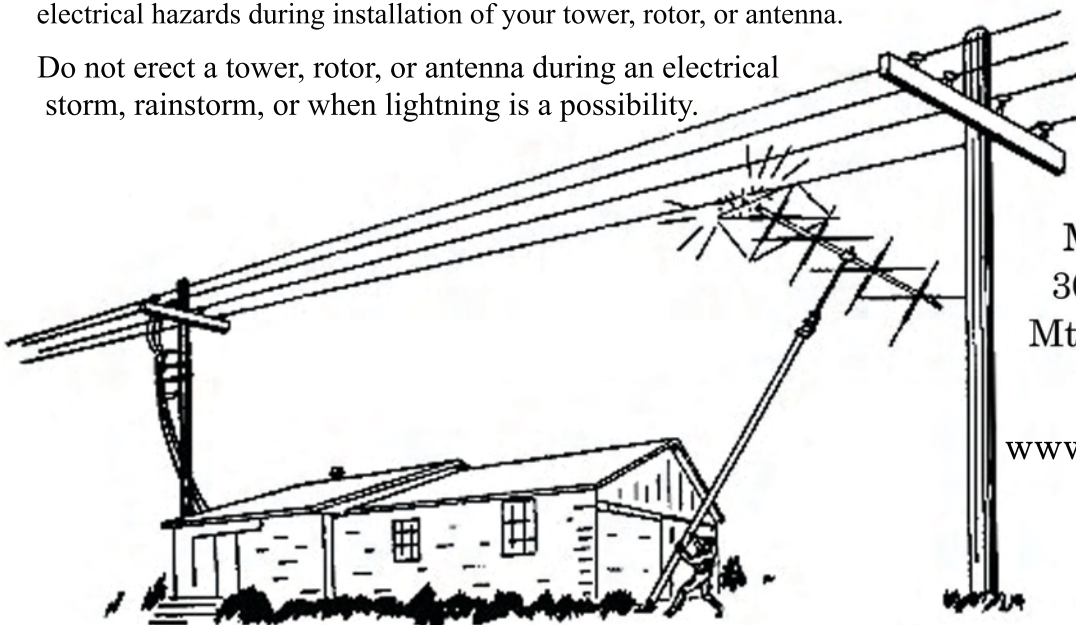

MACo Antennas
302 S. East Street
Mt. Carroll, IL 61053

www.macoantennas.net
(815) 244-3500

MACo Antennas is a Division of Charles Electronics, LLC