



# RM Costruzioni Elettroniche

di Marchioni Davide & Daniele s.n.c.

Via IV Novembre 215/5  
Casella postale N° 33  
40045 Ponte della Venturina (BO) ITALY  
Tel +39 0534 60460  
Fax +39 0534 60463  
E-MAIL [ufftec@rmitaly.com](mailto:ufftec@rmitaly.com)  
<http://www.rmitaly.com>

## KLV 250 linear amplifier

Schematic diagram

Version 5.00

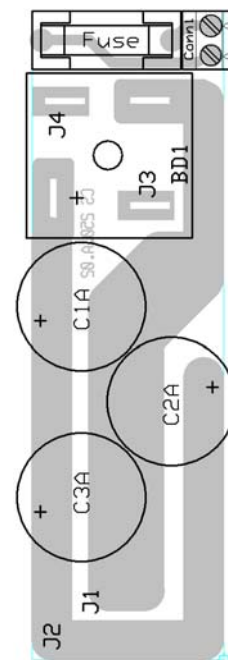
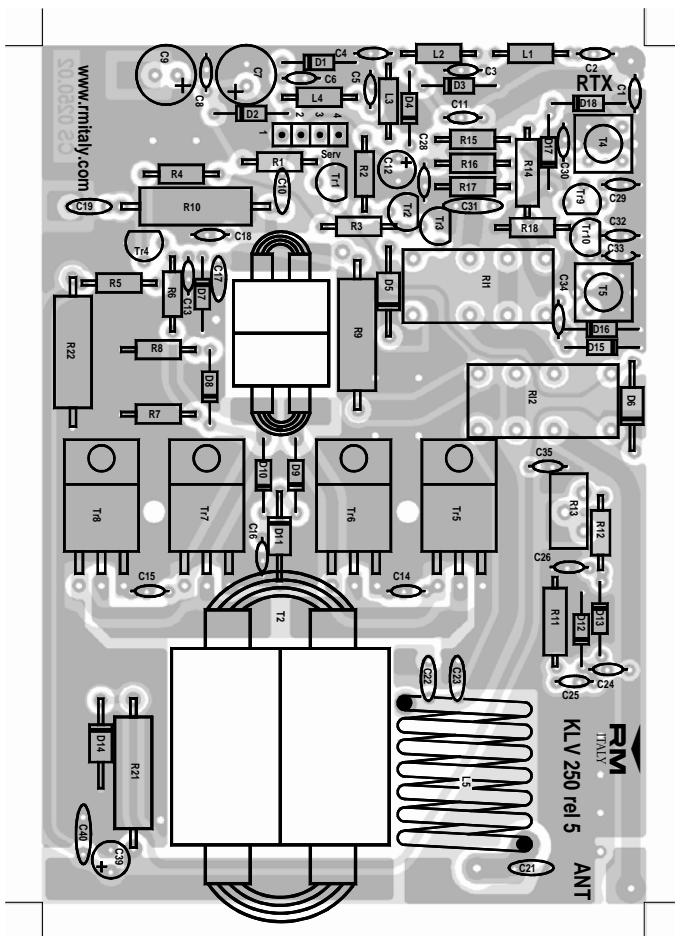
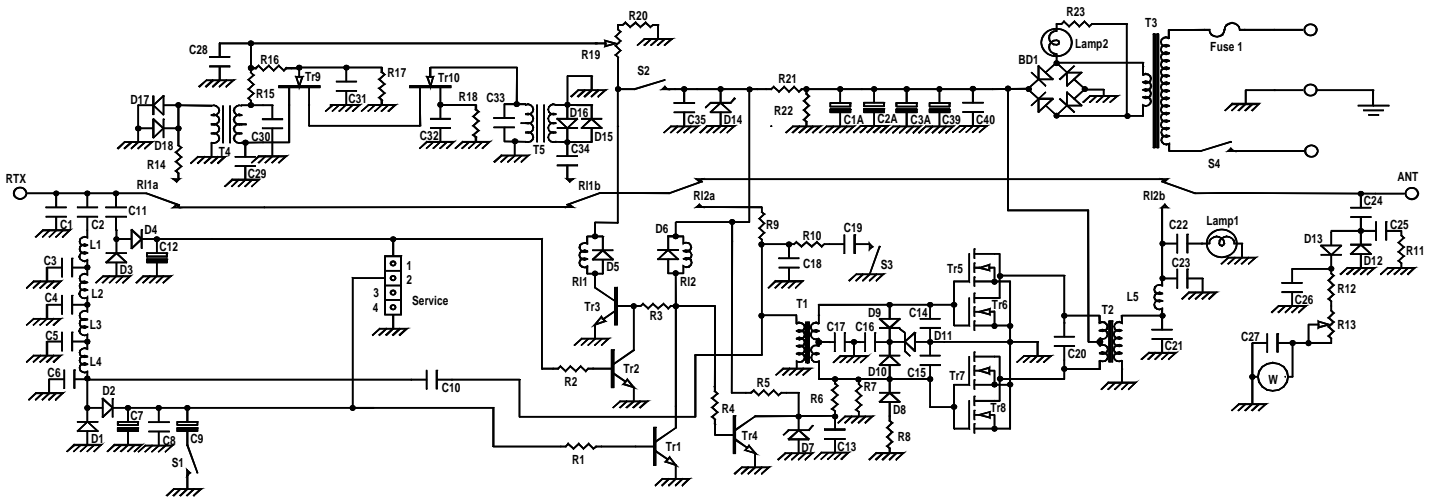

**List of components**

C <sub>1</sub> =			R <sub>9</sub> = 10 Ω	2W
C <sub>2</sub> = 3,3 pF	50 V	N750	R <sub>10</sub> = 47 Ω	2W
C <sub>3</sub> = 100 pF	50 V	N750	R <sub>11</sub> = 27 Ω	½W
C <sub>4</sub> = 100 pF	50 V	N750	R <sub>12</sub> = 47 KΩ	¼W
C <sub>5</sub> = 100 pF	50 V	N750	R <sub>13</sub> = Trimmer	220 KΩ
C <sub>6</sub> =			R <sub>14</sub> = 18 Ω	½W
C <sub>7</sub> = 2,2 μF	16 V		R <sub>15</sub> = 470 Ω	¼W
C <sub>8</sub> = 10 nF	50 V		R <sub>16</sub> = 56 KΩ	¼W
C <sub>9</sub> = 33 μF	16 V		R <sub>17</sub> = 22 KΩ	¼W
C <sub>10</sub> = 5,6 pF	50 V	N750	R <sub>18</sub> = 180 Ω	¼W
C <sub>11</sub> = 8,2 pF	50 V	N750	R <sub>19</sub> = Potenziometer	4,7 KΩ
C <sub>12</sub> = 10 μF	16 V		R <sub>20</sub> = 4,7 KΩ	¼W
C <sub>13</sub> = 10 nF	50 V		R <sub>21</sub> = 47 Ω	2W
C <sub>14</sub> = 150 pF	50 V	N750	R <sub>22</sub> = 330 Ω	2W
C <sub>15</sub> = 150 pF	50 V	N750	R <sub>22</sub> = 330 Ω	2W
C <sub>16</sub> = 10 nF	50 V		D <sub>1</sub> = D <sub>2</sub> = D <sub>3</sub> = D <sub>4</sub> = D <sub>8</sub> = D <sub>9</sub> = D <sub>10</sub>	= 1N4148
C <sub>17</sub> =			D <sub>12</sub> = D <sub>13</sub> = D <sub>15</sub> = D <sub>16</sub> = D <sub>17</sub> = D <sub>18</sub>	= 1N4148
C <sub>18</sub> =			D <sub>5</sub> = D <sub>6</sub>	= 1N4004
C <sub>19</sub> = 82 pF	50 V	N750	D <sub>5</sub>	= Zener 7,5 V ½W
C <sub>20</sub> = 56 pF	500 V	N750	D <sub>11</sub>	= Zener 20 V 1W
C <sub>21</sub> = 82 pF	500 V	N750	D <sub>14</sub>	= Zener 12 V 1W
C <sub>22</sub> = 3,9 pF	50 V	N750	BD1	= Bridge 60 V 25 A
C <sub>23</sub> = 47 pF	500 V	N750	Tr <sub>1</sub> = Tr <sub>2</sub> = Tr <sub>3</sub> = Tr <sub>4</sub>	= BC 547
C <sub>24</sub> = 2,2 pF	50 V	N750	Tr <sub>5</sub> = Tr <sub>6</sub> = Tr <sub>7</sub> = Tr <sub>8</sub>	= MOS RM3
C <sub>25</sub> = 33 pF	50 V	N750	Tr <sub>9</sub> = Tr <sub>10</sub>	= BF 245
C <sub>26</sub> = 100 nF	50 V		Rl <sub>1</sub> = Rl <sub>2</sub>	= Relè 12 V 3022
C <sub>27</sub> = 100 nF	50 V		Fuse	= 2A
C <sub>28</sub> = 10 nF	50 V		L <sub>1</sub>	= 2,2 μH
C <sub>29</sub> = 33 pF	50 V	N750	L <sub>2</sub>	= 2,2 μH
C <sub>30</sub> = 10 nF	50 V		L <sub>3</sub>	= 2,2 μH
C <sub>31</sub> = 10 nF	50 V		L <sub>4</sub>	= 2,2 μH
C <sub>32</sub> = 10 nF	50 V		L <sub>5</sub>	= 6 turns φ 15 mm wire φ 1,5 mm
C <sub>33</sub> = 27 pF	50 V	N750	Lamp <sub>1</sub>	= 24 V
C <sub>34</sub> = 10 nF	50 V		Lamp <sub>2</sub>	= Meter lamp
C <sub>35</sub> = 10 nF	50 V		S <sub>1</sub>	= Switch 3A (AM SSB)
C <sub>39</sub> = 33 μF	35 V		S <sub>2</sub>	= Switch 3A (Pre ON)
C <sub>40</sub> = 100 nF	50 V		S <sub>3</sub>	= Switch 3A (HI LOW)
C <sub>1A</sub> = 4700 μF	35 V		S <sub>4</sub>	= Switch 3A (ON OFF)
C <sub>2A</sub> = 4700 μF	35 V		T <sub>1</sub>	= Input transformer
C <sub>3A</sub> = 4700 μF	35 V		T <sub>2</sub>	= Output transformer
R <sub>1</sub> = 2,2 KΩ	¼W		T <sub>3</sub>	= Transformer IN 220V OUT 14V
R <sub>2</sub> = 2,2 KΩ	¼W		T <sub>4</sub> = T <sub>5</sub>	= Transformer 30 MHz
R <sub>3</sub> = 10 KΩ	¼W			
R <sub>4</sub> = 10 KΩ	¼W			
R <sub>5</sub> = 1,0 KΩ	¼W			
R <sub>6</sub> = 10 KΩ	¼W			
R <sub>7</sub> = 3,3 KΩ	¼W			
R <sub>8</sub> = 1,0 KΩ	¼W			