

# ALIGNMENT PROCEDURE

Downloaded from [www.cbradio.nl](http://www.cbradio.nl)

MODEL: 19DX III

REVISION: 00

DATE : AUGUST 15, 2000

PREPARED BY: \_\_\_\_\_

CHECKED BY: \_\_\_\_\_

APPROVED BY: \_\_\_\_\_

TOTAL PAGES:

## 19DX3 ALIGNMENT INSTRUCTION

**1.0 TEST CONDITION:**

1.1. STANDARD DC POWER:	EXT.DC	13.8VDC
1.2. MEASUREMENT CHANNEL:	CB	CH19 (27.185MHz)
1.3. STANDARD AUDIO LOADING:	CB	8 $\Omega$
1.4. ANTENNA IMPEDANCE:	CB	50 $\Omega$
1.5. STANDARD REF. MODULATION:	CB	30% (AM)
1.6. STANDARD REF. AUDIO OUTPUT:	CB	0.5W

**1.7. FREQUENCY TABLE**

CB BAND	
CH NO.	FREQ. (MHz)
01	26.965
02	26.975
03	26.985
04	27.005
05	27.015
06	27.025
07	27.035
08	27.055
09	27.065
10	27.075
11	27.085
12	27.105
13	27.115
14	27.125
15	27.135
16	27.155
17	27.165
18	27.175
19	27.185
20	27.205
21	27.215
22	27.225
23	27.255
24	27.235
25	27.245
26	27.265
27	27.275
28	27.285
29	27.295
30	27.305
31	27.315
32	27.325
33	27.335
34	27.345
35	27.355
36	27.365
37	27.375
38	27.385
39	27.395
40	27.405

**1.8. TEST EQUIPMENT SETUP AS BELOW:**

A. TX test equipment setup:

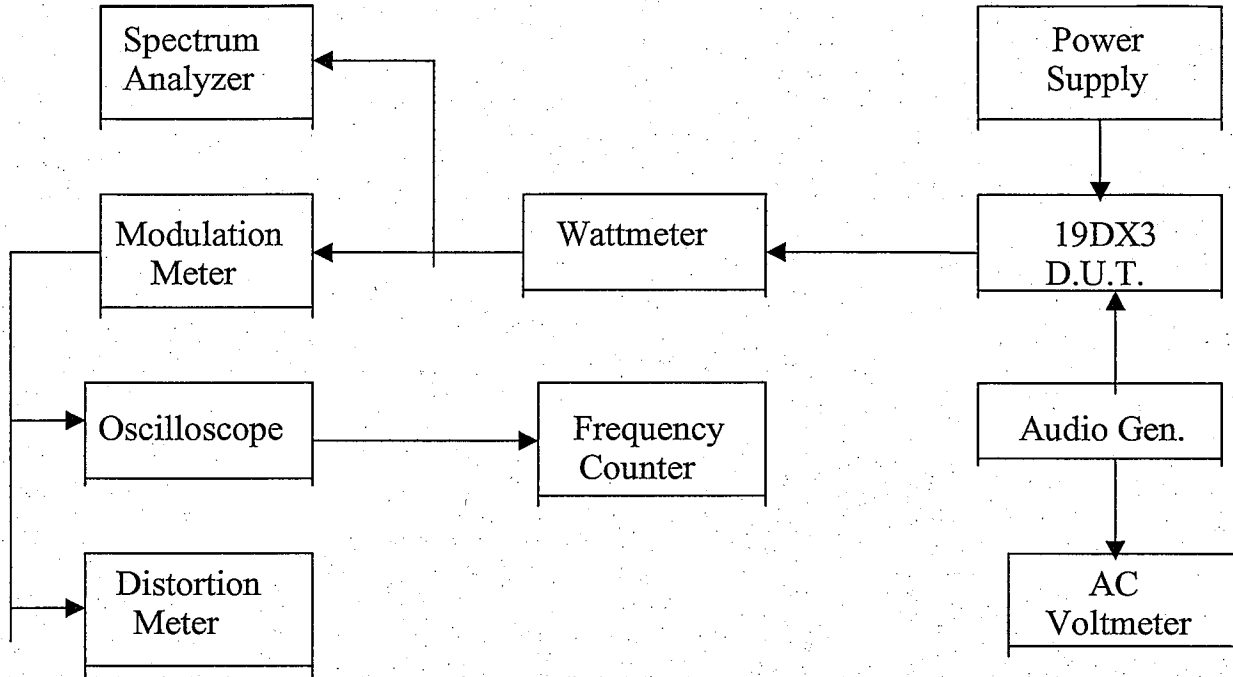

B. RX test equipment setup:

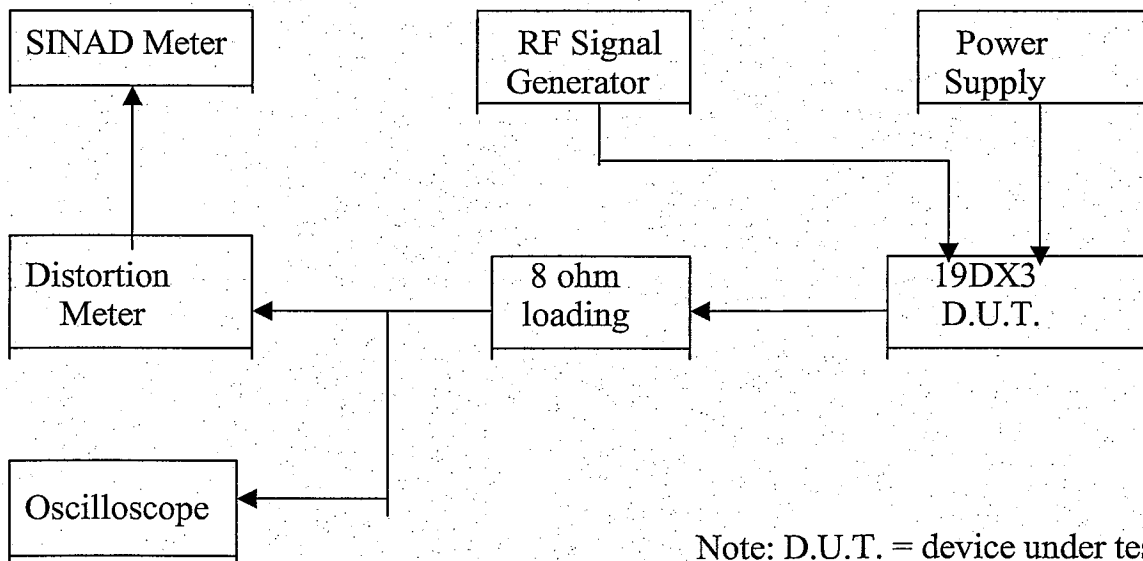

Note: D.U.T. = device under test

## 2.0 ALIGNMENT

### 2.1 VCO ALIGNMENT

TEST ITEM	TEST CONDITION & PROCEDURE	PURPOSE
CB VCO Voltage	1. Connect a digital multi-meter to TP1	Adjust <b>L11</b> for $1.5 \pm 0.1$ V.
	2. Set CB RX mode: CH1.	
	3. Set CB TX mode	Check CH40 $\leq 4.5$ V.

### 2.2 CB Receiver Alignment

TEST ITEM	TEST CONDITION & PROCEDURE	PURPOSE
1. Audio output level	<ol style="list-style-type: none"> <li>1. CB RX mode.</li> <li>2. Output of signal generator thru 0.01uF to TP3.</li> <li>3. RF Gen. set 10.7MHz, Fmod= 1KHz, AM= 30%, level: 1mV.</li> <li>4. Set Volume control to middle position.</li> <li>5. Set Squelch to minimum.</li> </ol>	<ol style="list-style-type: none"> <li>1. Adjust <b>L8</b> and <b>L23</b> for maximum audio output &amp; minimum distortion at the distortion meter.( Distortion less than 5% )</li> <li>2. Set volume control to maximum position, audio power output shall be more than 3 Watts.</li> </ol>
2. RX sensitivity	<ol style="list-style-type: none"> <li>1. Set normal band CH19.</li> <li>2. Output of signal generator to antenna input terminal.</li> <li>3. RF Gen. set 27.185MHz, fm: 1kHz, AM= 30%, RF level: 1uV.</li> </ol>	<ol style="list-style-type: none"> <li>1. Adjust <b>L5</b>, <b>L6</b> and <b>L10</b> for more than 10dB S/N ratio.</li> <li>2. Repeat as needed. Check CH1 and CH40.</li> </ol>
3. SQUELCH control ( Tight Squelch )	<ol style="list-style-type: none"> <li>1. Set normal band CH19.</li> <li>2. Output of signal generator to the antenna input terminal.</li> <li>3. RF Gen. set 27.185 MHz , Fmod= 1KHz, AM= 30%, RF level: 2500 uV.</li> <li>4. Rotate the Squelch control to fully clockwise position</li> </ol>	<ol style="list-style-type: none"> <li>1. Slowly turn <b>VR5</b> to a position that the audio output waveform at the oscilloscope just appears from no output.</li> <li>2. Must open at 4000uV.</li> <li>3. Must not open at 800uV.</li> </ol>
4. Signal meter display	<ol style="list-style-type: none"> <li>1. Set normal band CH19.</li> <li>2. Output of signal generator to antenna input terminal. RF Gen. set 27.185MHz, no modulation, RF level: 100 uV.</li> </ol>	<ol style="list-style-type: none"> <li>1. Adjust <b>VR1</b> for "9" displayed on the signal meter of LED panel.</li> <li>2. Increase RF level by 30dB. The signal meter should be displayed at "+30" position.</li> </ol>

### 2.3 CB Transmitter Alignment

TEST ITEM	TEST CONDITION & PROCEDURE	PURPOSE
1. TP4 Alignment	<ol style="list-style-type: none"> <li>Channel set normal band CH 19.</li> <li>Set TX mode. Connect the TP4 (IC8 pin9) thru a 10pF capacitor to the oscilloscope.</li> </ol>	<ol style="list-style-type: none"> <li>Adjust <b>L21, L22</b> for maximum RF output waveform at the scope.</li> <li>Repeat as needed.</li> </ol>
2. TX Carrier output power	<ol style="list-style-type: none"> <li>Channel set normal band CH 19.</li> <li>Set TX mode.</li> <li>Connect an RF wattmeter to the antenna socket.</li> </ol>	<ol style="list-style-type: none"> <li>Adjust <b>L21, L22</b> and <b>L17</b> for 4.0 watts RF output power.</li> <li>Check TX CH1 and CH40 should meet D.T.S.</li> </ol>
3. TX Carrier frequency	<ol style="list-style-type: none"> <li>Channel set CH 19.</li> <li>Set TX mode.</li> </ol>	Adjust <b>VC1</b> for 27.185000MHz at the frequency counter.
4. TX Signal meter	<ol style="list-style-type: none"> <li>Connect an RF wattmeter to the antenna socket.</li> <li>No modulation.</li> <li>Set TX output power for 3watts.</li> </ol>	Adjust <b>VR6</b> for "4" displayed at the TX signal meter of the LED panel. (red LED)
5. MAXIMUM Modulation (AMC control)	<ol style="list-style-type: none"> <li>Set TX mode. Output of AF generator to MIC jack, @ 1000Hz, 5 mV .</li> </ol>	<ol style="list-style-type: none"> <li>Adjust <b>VR2</b> for 89-91% modulation.</li> <li>Distortion less than 8.0% at 80% modulation.</li> <li>Check CH1, CH40.</li> </ol>
7. Occupied band width, (OBW)	<ol style="list-style-type: none"> <li>Set TX High power mode</li> <li>Set modulation frequency 2500 Hz.</li> </ol>	The frequency spectrum of the harmonics should be at least 2 dB better than the limits of the FCC specification.

# BLOCK DIAGRAM FOR CB 19 PAYTON

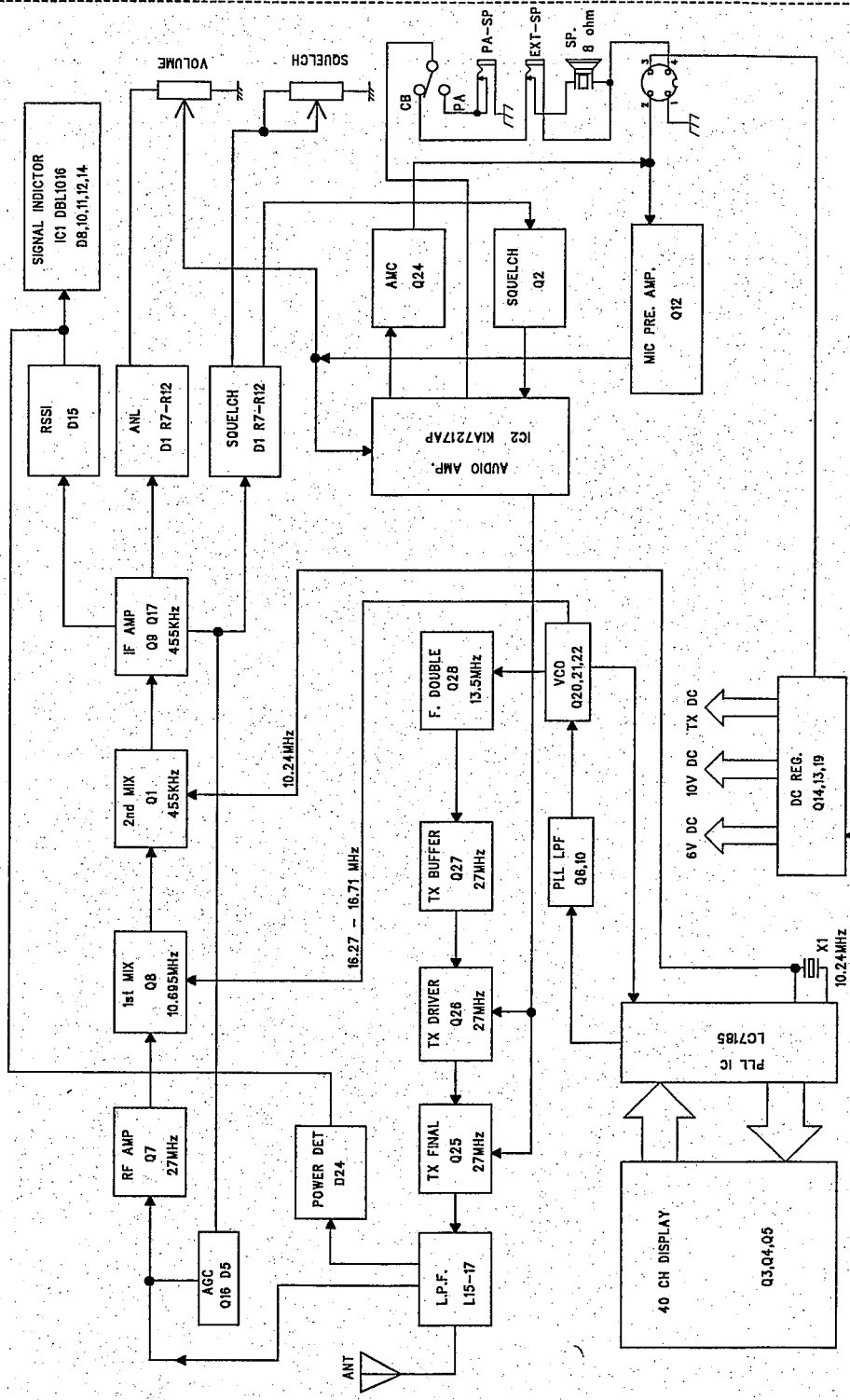

TITLE:	BLOCK DIAGRAM FOR CB PAYTON
DRAWN:	XW PENG
DATE:	APR-08-2000
VER:	00
APPROVED:	
FILE NAME:	19BL

COMPANY:

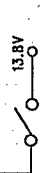

103mm

147.5mm

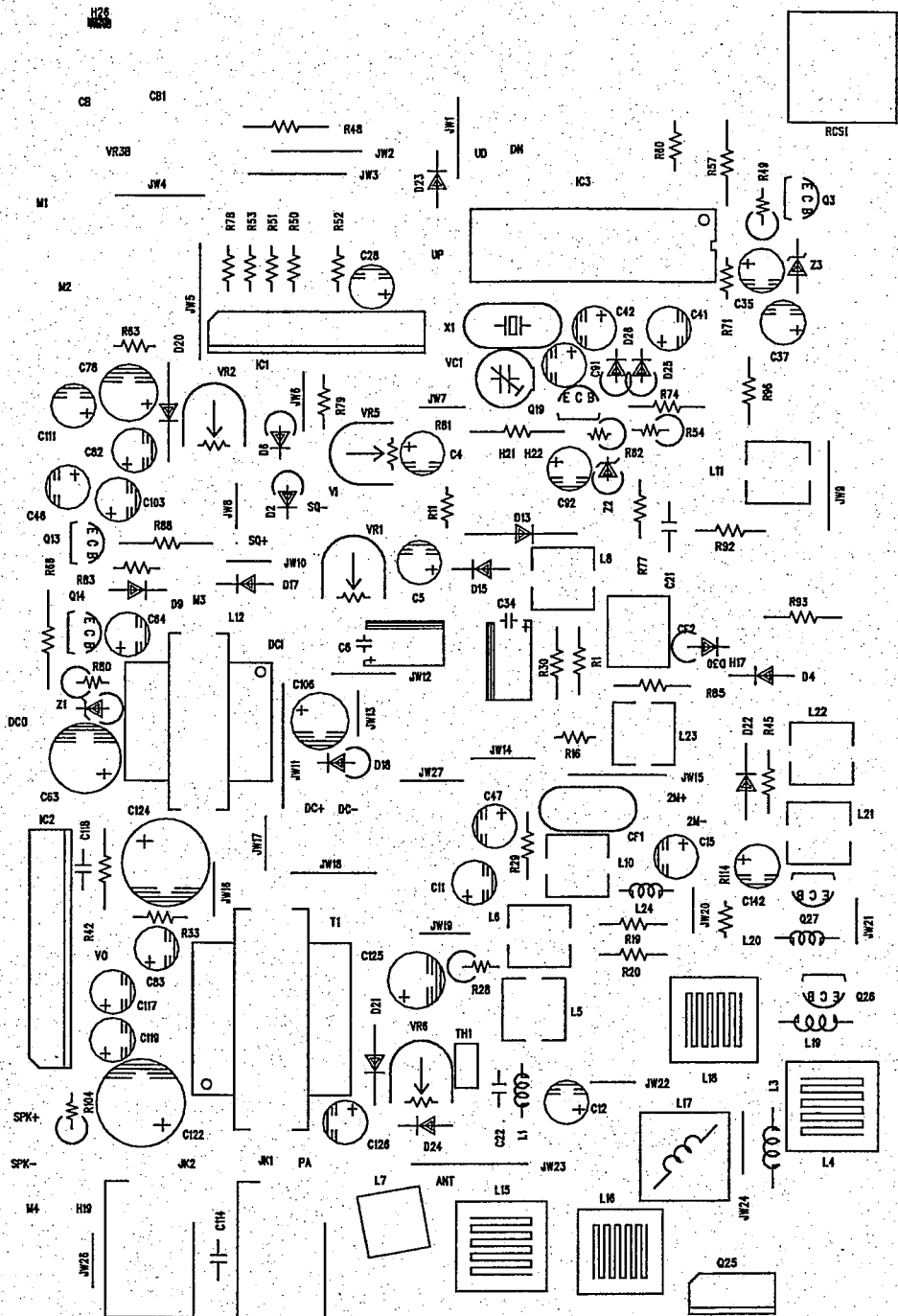

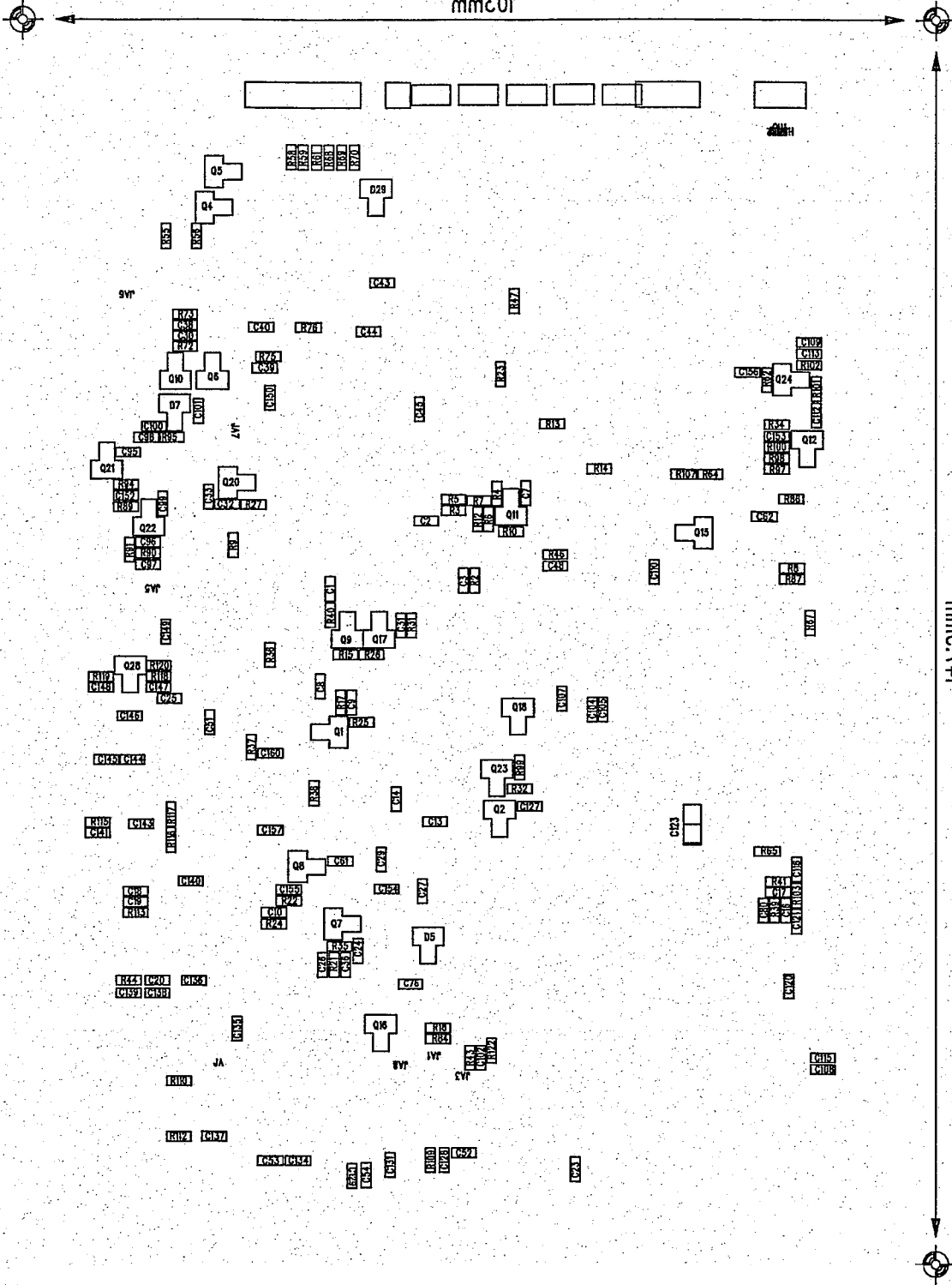





# CIRCUIT DIAGRAM FOR COBRA CB 19DX3

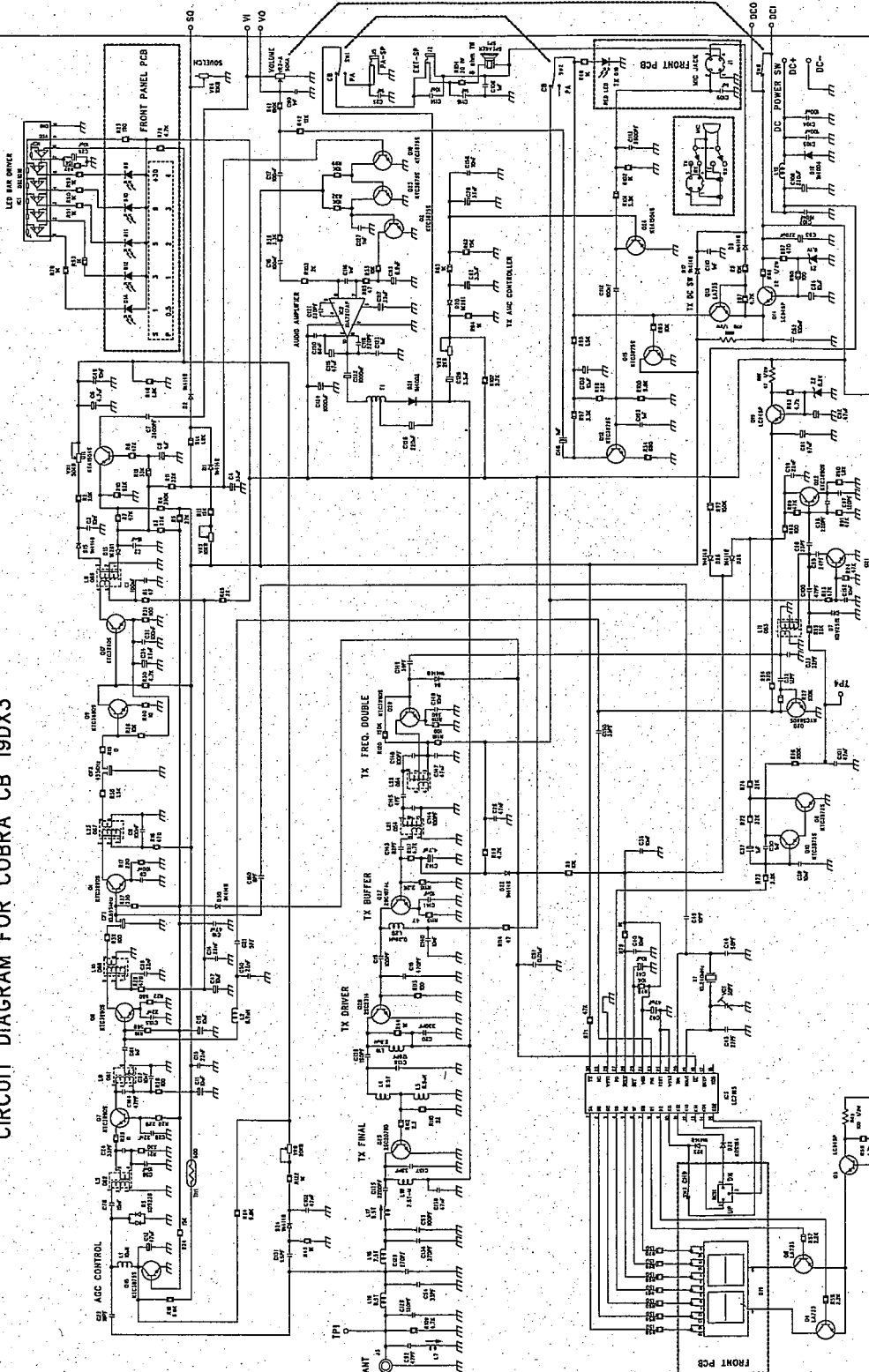

REV.	DATE	BY	CHKD.	APP'D.
1	10-15-50	W. J. HARRIS	W. J. HARRIS	W. J. HARRIS

CIRCUIT DIAGRAM FOR COBRA CB 19DX3

FILE NO.	REV.	DATE	BY	CHKD.
100-103-1000	1	10-15-50	W. J. HARRIS	W. J. HARRIS

TO 100-103-1000