

www.cbradio.nl

CONCORDE 2 thanks Homer

for sharing this file

SERVICE MANUAL



HAM INTERNATIONAL

Specifications

General

Frequency composition : Digital Phase-Locked Loop Synthesizer
Channels: 120 (80 + 40)
Operating Mode : AM, FM, USB, LSB, CW.
Power Source: 13.8 V DC (Negative or positive ground)
Antenna Impedance: 50 Ohm (SO-239 receptacle)
Dimensions: Width; 195 mm
Height; 65 mm
Depth; 275 mm
Weight: 3.15 kg

Receiver

Conversion System: AM/FM: Dual conversion superheterodyne
SSB : Single conversion
Sensitivity:
AM: 0.7 μ V at 10 dB S/N
FM: 0.5 μ V at 20 dB S/N
SSB: 0.2 μ V at 10 dB S/N
Selectivity:
AM/FM: 6 kHz at 6 dB down
SSB: 2 kHz at 6 db down
Clarifier Range: \pm 4.5 kHz
Tune Range: \pm 4.5 kHz minimum
Audio Output: 3.5 W to 8 Ohm, 10 % THD
Squelch Range: 0.7 to 300 uV (all modes)

Transmitter

RF Power output: AM: 4 W/0.5 W
FM: 4 W/0.5 W
SSB: 12 W (PEP)
AM Modulation Level: 100 %
FM Deviation: 1.5 kHz at 1,250 Hz and 20 mV audio
SSB Generation: Double balanced modulator with crystal lattice filter
Carrier Suppression: 40 dB down
Unwanted Sideband Suppression: 60 dB down
Harmonic and Spurious Suppression: 60 dB down

Circuit description

The transceiver is a 120 channel CB radio which uses a Phase Locked Loop [PLL] system of frequency synthesization to produce the crystal controlled channel and IF signals used in operation of the transmitter and receiver sections of the unit. The basic PLL system is comprised of a free-running voltage controlled oscillator (part of IC-2), a phase detector, a reference crystal oscillator (Q-3) and a programmable divider (IC-1).

PLL circuit

The voltage controlled oscillator [VCO] operates in the frequency range of 17.555 to 18.445 MHz in the AM/FM/USB modes and 17.552 to 18.442 MHz in the LSB mode, and is used to produce two output signals: #1, 37.660 to 39.000 MHz in the AM/FM/USB modes and 37.657 to 38.997 MHz in the LSB mode, #2, at 2.55 to 2.11 MHz. Reference frequency oscillator Q-4 oscillates at 20.105, 20.330 or 20.555 MHz in accordance with the Band Selector switch (1.5 kHz lower in LSB mode). Its output is fed through the band-pass filter [BPF]. This signal beats with the VCO free-running signal producing a 37.66 to 39.00 MHz in the AM/FM/USB modes and 37.657 to 38.997 MHz in the LSB mode, which is fed to the receiver first mixer [Q-22] and also to IC-3 (on Main circuit board PTBM121), the transmitter mixer. The second VCO output signal, at 2.55 to 2.11 MHz is fed to the programmable divider in IC-1. Simultaneously the 10.24 MHz output of Q-3 [through the buffer Q-2] is applied to the programmable divider in IC-1 and is divided down in 10 kHz steps. A channel is chosen by the Channel Selector switch [SW-1 b on PTSW076], and a N-code signal is applied to the terminals [pin No.10 to 15 of IC-1] on the programmable divider in IC-1, to preset the divider. The two signals, the crystal oscillated signal [10.24 MHz] from Q-2, and the signal from the VCO via the lowpass filter [LPF] and buffer [in the IC-1], are compared in the phase detector of IC-1 and the phase detector produces a DC output voltage derived from the phase difference in the signals fed to it. This DC output is applied through an LPF to the VCO, forming the phase loop. This DC voltage applied to the VCO causes it to shift frequency until its output signal locks up with the count-down frequency provided from reference

oscillator Q-3 [when two signals are in phase] at which point no DC output is produced in the phase detector, and the VCO remains locked on frequency. When a new channel is selected a new 'N' code is applied to the programmable divider. The VCO is no longer locked because of the resulting phase difference in the phase detector, and it again shifts frequency to a locked condition, in turn producing 37 MHz output signals corresponding to the new channel programmed by the new 'N' code. In summary it will be seen that a stable VCO frequency range will be produced, each specific frequency being determined by the 'N' code selected by the Channel Selector switch.

Main board assembly (PTBM121)

The crystal oscillator Q-11 is operating at 10.695 MHz in the AM/FM/USB modes, and 10.692 MHz in the LSB mode, controlled by the crystal, X-3. This signal is #1; in the AM and FM modes of transmission, fed to the IC-3 to mixed with the first Tx local oscillator frequency and results in 27 MHz transmitter frequencies, and #2; in the SSB mode of transmission, modulated through the balanced modulator IC-4 with the audio output signal from the microphone amplifier, IC-5. The resultant output of the balanced modulator is a double sideband, suppressed carrier signal. The crystal filter XF pass band is restricted to 3.5 kHz so that it allows only one sideband to pass through its output terminals, either USB or LSB mode, depending upon the Mode Selector switch selection. The exact frequency of which was determined by the Channel Selector switch selection and the PLL circuitry, as previously outlined, the resultant frequency, therefore, that is fed to the RF amplifier in IC-3, is the channel frequency on the channel selected [channel 1 through 120 over 26.965 to 28.305 MHz]. The 27 MHz RF amplifier output is coupled to RF predriver transistors, Q-7, Q-8 through T-4, T-5. The predrivers serve to isolate the oscillator and mixer stages from the output amplifiers, and at the same time provide a certain amount of power gain. Q-8 output is applied to the base input of Q-9, the RF driver stage and in turn to the Q-10, the RF power output stage of the transmitter. These stages amplify the 27 MHz signal resulting in an output of 4 Watts in the AM/FM modes, and 12 Watts PEP [peak envelope power] in the SSB mode.

Modulation circuit

- AM: The microphone feeds voice audio through Q-34 to the power audio IC IC-5, and finally to collector of Q-9 and final RF power amplifier Q-10 through Q-36 thereby amplitude modulating the carrier in AM transmission.
- FM: In the FM mode, IC-5 output is fed to the anode of the variable capacitor D-4 in IC-2 VCO circuit, varying its bias to change VCO signal phase component, finally giving deviation to PLL output frequency.
- SSB: The IC-5 output is directly fed to the balanced modulator IC-4, resulting in suppressed carrier double side band, which is in turn supplied to the crystal filter to carrier removal.
- ALC: An audio ALC [automatic level control] voltage derived from the audio signal at Q-35 is fed to IC-5 to control the output of audio amplifier to prevent overmodulation. The transceiver is also equipped with the RF ALC circuit utilizing the RF output induced at the input of L-13 [in the SSB mode only]. The minus voltage detected through D-10 is applied to the DC plus bias circuit [pin No.7 of IC-3, TX mixer] thus reducing the gain of the TX mixer as high level RF signal is observed at L-13. This circuit is disabled in the AM or FM mode of transmission. The ALC circuit [both audio and RF] accomplishes very important function, not only preventing overmodulation, but in the view of harmonic and spurious suppression [especially in the SSB transmit mode].

Antenna Transmission Line

The lowpass filter between the antenna and collector of Q-10 serves to pass the 27 MHz signals, attenuating higher frequency signals. It also acts to match the antenna impedance to the output impedance of the transmitter output stage, this nominally being 50 Ohms.

SWR circuit

The SWR circuit (of this unit) employs a "Bridge" circuit which is suited for SWR measurement. D-502, C-502 detect forward wave and also D-501, C-501 detect reflective wave in the transmission line.

Receiver circuit

The RF signal, at a frequency between 26.965 to 28.305 MHz, feeds from the antenna through L-14, 13, 12 and T-7 to the 27 MHz RF amplifier Q-20. Then the amplified output signal from Q-20 is coupled through T-10 to first mixer Q-22 where it beats with an injection signal from IC-2 depends on the channel being selected, as a signal of the 37 MHz range is programmed by the Channel Selector. The output of Q-22 is therefore, 10.695 MHz in the AM/FM/USB modes, and 10.692 MHz in the LSB mode, the first intermediate frequency and is the result of the RF input and mixing of IC-2 VCO signals. In case of the AM or FM receive mode, this 10.695 MHz first IF signal is then fed to the second mixer, balanced D-23 and D-24. Also fed to the second mixer is the second local oscillator signal, 10.24 MHz, from Q-3. Mixing of these two signals results in a signal at a frequency of 455 kHz in T-14. This is the second intermediate frequency for AM or FM mode of reception. In AM mode, the 455 kHz signal passes through the ceramic bandpass filter CF, and is fed to IF amplifiers Q-27, 28 and 29, which include detector, while in FM receiving mode, the 455 kHz signal amplified only through demodulated audio is achieved from the IC pin #12 and input to AF gain control VR, VR-1. In the SSB mode of reception, the signal obtained as a result of the mixing of the RF input and IC-2 VCO signals, 10.695 MHz in the USB, and 10.692 MHz in the LSB mode, is not converted down to lower intermediate frequency, but is passed through the crystal filter, XF, and fed to the SSB IF amplifiers, A-14, 16 and 17 which includes T-7, and 8. The signal at the secondary side of T-8 is fed to Q-19, the product SSB detector and beats with the BFO [beat frequency oscillator] signal from the Q-11 and finally rectified to audio frequency signal. The audio signal output from detectors (for AM [D-25], FM [IC-6], and SSB [Q-19]), is passed through the AF Gain Control, VR-1, to the input

of the audio amplifier, Q-34. The audio output is coupled to the terminal speaker through or to an external speaker through External Speaker Jack, J-3.

Squelch circuit

Q-31, 32 and 33 are the squelch amplifier transistors. At low (or no) signal levels Q-33 collector conducts to ground and its output connected of pin No.7 of IC-5 results in no signal out from the audio amplifier. As the incoming RF signal increases it results in opening up the AF amplifier and output is activated. The level at which Q-33 cuts off is determined by setting of the Squelch Control, VR-2.

Clarifier circuit

The Clarifier is operative only in receive mode and changes the receiving frequency regardless of the transmitting frequency. VR-4 acts to vary the plus bias voltage of D-1 (on circuit board PTOS012). Thus, Q-1 oscillating frequency is pulled above (VR-4 clockwise rotated) or down (VR-4 counterclockwise rotated) its normal channel frequency. D-1 is fixed bias when the unit is transmitting.

Noise blanker circuit

The noise contained in the RF signal at the output of RF amplifier, Q-20, is fed through C-117 to the base of Q-23. The amplified signal output of Q-23 is rectified by diodes D-21 and 22. The resulting DC voltage turns on Q-24 [FET] which in turn turns on Q-25 and 26. This causes the IF signal [10.695 or 10.692 MHz] at T-12 to be connected to ground through C-125 and Q-26 during the presence of the noise impulses, blanking out the noise from the audio output.

Alignment Procedure

1. Measurement condition.

- 1) Reference temperature : 25 °C.
- 2) Reference humidity : 65 %.

NOTE: Unless otherwise specified, alignment may be performed under the room temperature of 5 - 35 °C and the room humidity of 45 - 80 %.

3) Power supply

DC 13.8 V \pm 1 %, unless otherwise specified.

2. Test equipment.

- | | | |
|------------------------------|------|--|
| a) Audio Signal Generator | OSC | Sine wave, 10 Hz - 20 kHz. |
| b) Audio Level Meter | VV | 1 mV measurable. |
| c) DC Ampere Meter | A | DC 3 A. |
| d) Regulated Power Supply | B | DC 0 - 20 V, 3 A or higher. |
| e) Frequency Counter | FC | 0 - 40 MHz, high input impedance. |
| f) RF VTVM | VTVM | Probe type. |
| g) Oscilloscope | CRT | 30 MHz, high input impedance. |
| h) RF Wattmeter | W | Thermo-couple type, 50 Ohms, 15 W. |
| i) Standard Signal Generator | SG | 100 kHz - 50 MHz, -10 - 100 dB,
50 Ohms unbalanced. |
| j) Speaker Dummy Load | R | 8 Ohms, 5 W. |
| k) Circuit Tester | T | DC 20 kOhms/V, High input impedance
type (20 kOhms/V or higher). |

All test equipment should be properly calibrated.

3. Transmitter alignment.

3.1 Test set-up.

Connect test equipment to the unit as shown:

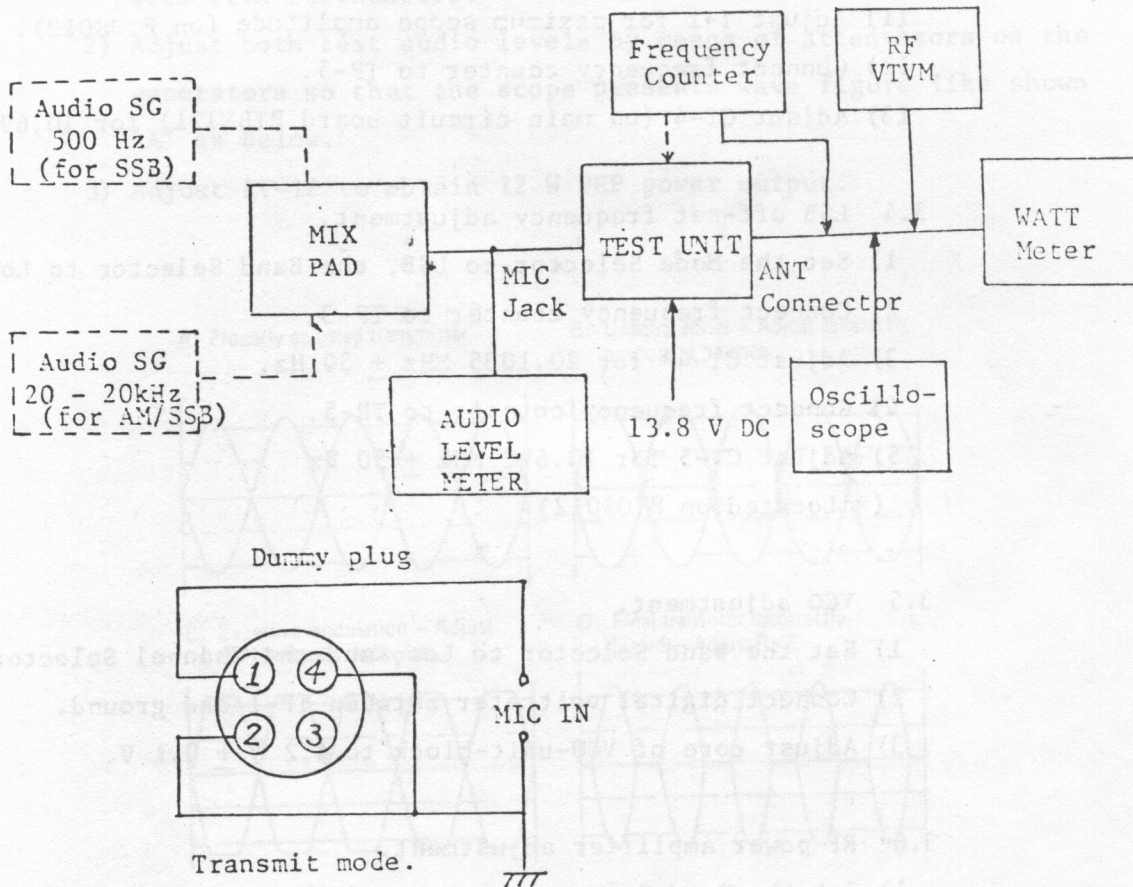

3.2 PLL adjustment.

- 1) Connect frequency counter to TP-2 (or IC-1 #3) through 1,000 pF capacitor.
- 2) Adjust CT-1 for 10.240 MHz. Tolerance within ± 50 Hz is acceptable.

3.3 Off-set frequency adjustment.

- 1) Connect frequency counter to TP-3, with maximum level range.
- 2) Set the Mode Selector to USB.
- 3) Set the Band Selector to Low.
- 4) Adjust CT-1 for 20.105 MHz ± 40 Hz (on PTOS012).
- 5) Set the Band Selector to Mid.
- 6) Adjust CT-2 for 20.330 MHz ± 40 Hz (on PTOS012).

- 7) Set the Band Selector to Hi.
- 8) Adjust CT-3 for $20.555 \text{ MHz} \pm 40 \text{ Hz}$ (on PTOS012).
- 9) Set the Band Selector to Mid, the channel selector to 60.
- 10) Connect scope to TP-3.
- 11) Adjust T-1 for maximum scope amplitude (on PTOS012).
- 12) Connect frequency counter to TP-5.
- 13) Adjust CT-4 (on main circuit board PTBM121) for $10.695 \text{ MHz} \pm 50 \text{ Hz}$

3.4 LSB off-set frequency adjustment.

- 1) Set the Mode Selector to LSB, the Band Selector to Low.
 - 2) Connect frequency counter to TP-3.
 - 3) Adjust CT-4* for $20.1035 \text{ MHz} \pm 50 \text{ Hz}$.
 - 4) Connect frequency counter to TP-5.
 - 5) Adjust CT-5 for $10.692 \text{ MHz} \pm 50 \text{ Hz}$
- (* Located on PTOS012)

3.5 VCO adjustment.

- 1) Set the Band Selector to Low, and the Channel Selector to 1.
- 2) Connect digital voltmeter between TP-1 and ground.
- 3) Adjust core of VCO-unit-block to $4.2 \text{ V} \pm 0.1 \text{ V}$.

3.6 RF power amplifier adjustment.

- 1) Set the Band Selector to Low and the Channel Selector to 1.
- 2) Set the Mode switch to USB.
- 3) Feed 2,400 Hz 10 mV audio to the unit (use dummy microphone plug prewired).
- 4) Adjust T-3 and T-5 for maximum scope display.
- 5) Set the Band Selector to Hi and the Channel Selector to 40.
- 6) Adjust T-2 and T-4 for maximum scope display.

3.7 Carrier leakage adjustment.

- 1) Set the Band Selector to Mid and the Channel Selector to 60.
- 2) Feed 2,400 Hz 10 mV audio to the unit.
- 3) Adjust T-6, L-12, L-13 and L-14 for maximum output on RF wattmeter.
- 4) Remove test audio.
- 5) Adjust RV-5 and RV-6 for minimum leakage on scope.

3.8 Two-Tone adjustment.

- 1) Feed 500 Hz and 2,400 Hz audio tones to the microphone input circuit at the same time. Use two audio signal generator sets with attenuators.
- 2) Adjust both test audio levels by means of attenuators on the generators so that the scope presents wave figure like shown 'A' as below.
- 3) Adjust RV-12 to obtain 12 W PEP power output.

A. Properly adjusted transmitter.

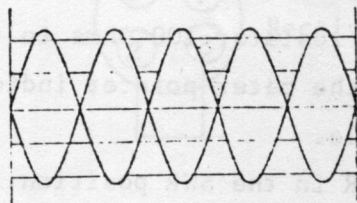

B. Unequal tones - Adjust generator outputs to balance.

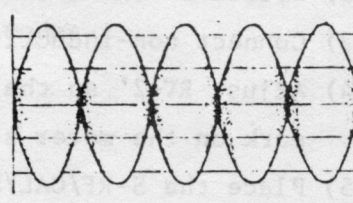

C. Excessive modulation - Adjust RV12 counterclockwise.

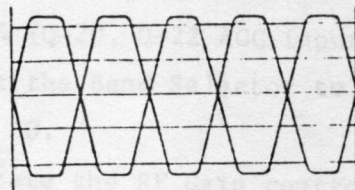

D. Final transistor incorrectly biased - Adjust RV2.

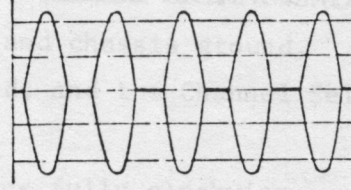

E. Undermodulation - Adjust RV12 clockwise.

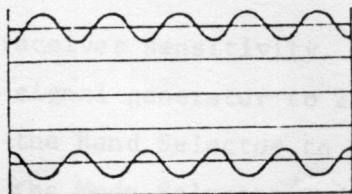

F. Similar to A but showing hum - Check for proper testing condition.

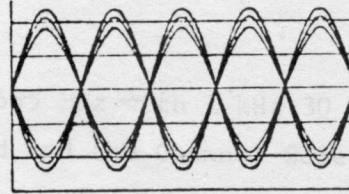

3.9 AM RF adjustment.

- 1) Set the Mode Selector to AM.
- 2) Select the Band Selector to Mid.
- 3) Select the Channel Selector to 60.
- 4) Adjust RV-14 for 4 W RF power output.

3.11 FM modulation adjustment.

- 1) Set the Mode Selector to FM.
- 2) Feed 2,400 Hz 10 mV audio to modulation circuit. Use dummy microphone plug.

3.12 RF power meter adjustment.

- 1) Set the unit to AM.
- 2) Comparing the external RF power the built-in meter, RV-3 for equal indication on the power meter.

3.13 SWR meter circuit adjustment.

- 1) Set the unit to AM.
- 2) Select S-RF/CAL/SWR switch to CAL position.
- 3) Connect non-inductive resistor 100 Ohms to the ANT terminal.
- 4) Adjust RV-2' so that the meter pointer indicates exact "SET" mark on the meter scale.
- 5) Place the S-RF/CAL/SWR in the SWR position.
- 6) Adjust RV-501 so that the meter pointer indicates "2" on the SWR meter scale.

4. Receiver alignment.

4.1 Test set-up.

Connect test equipment to the unit as shown:

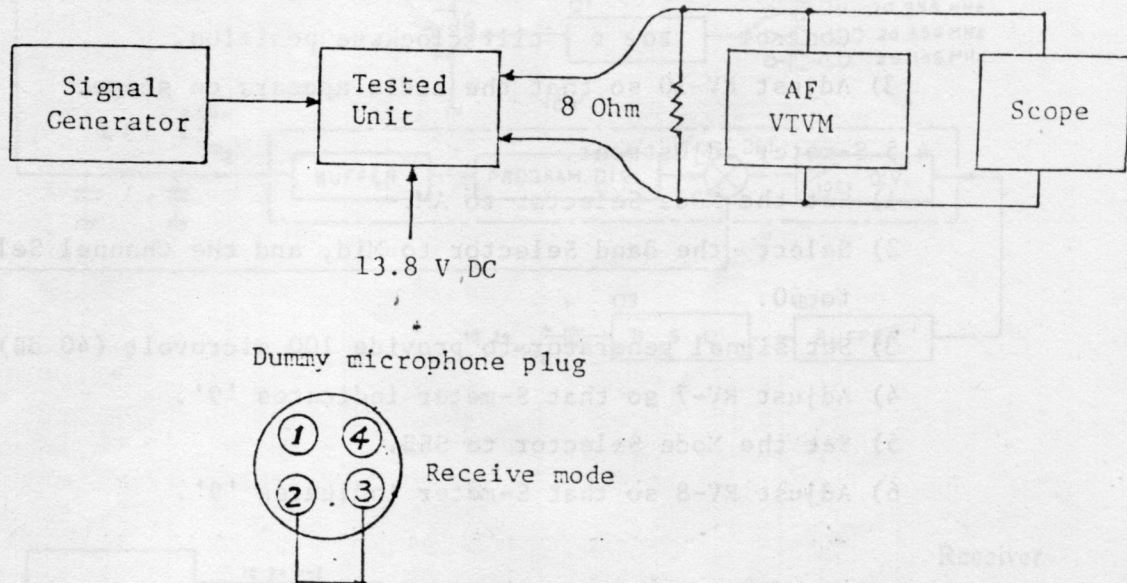

4.2 AGC adjustment.

- 1) Connect digital voltmeter to circuit board PTBM121 terminal #14 (Q-20, Q-22 AGC input) and chassis ground.
- 2) Set the Band Selector to Mid, and the Channel Selector to 60.
- 3) Rotate the RF Gain controller fully clockwise.
- 4) Adjust RV-9 for 2 V.

4.3 AM receiver sensitivity.

- 1) Set signal generator to 27.655 MHz with 1 kHz 30 % modulation.
- 2) Set the Band Selector to Mid and the Channel Selector to 60.
- 3) Set the Mode Selector to AM.
- 4) Adjust T-9, T-10, T-11, T-12, T-13, T-14 and T-15 for maximum audio output from speaker output terminals (across dummy load).

NOTE: Keep generator output level as low as possible to avoid AGC action.

- 5) After completion above, rotate T-9 to decrease the audio by 2 dB.

4.4 Squelch adjustment.

- 1) Set the Mode Selector to AM.
- 2) Set signal generator to provide RF input signal of 300 microvolt 1 kHz 30 % modulated, and rotate Squelch Control to fully clockwise position.
- 3) Adjust RV-10 so that the audio appears on scope.

4.5 S-meter adjustment.

- 1) Set the Mode Selector to AM.
- 2) Select the Band Selector to Mid, and the Channel Selector to 60.
- 3) Set signal generator to provide 100 microvolt (40 dB) output.
- 4) Adjust RV-7 so that S-meter indicates '9'.
- 5) Set the Mode Selector to SSB.
- 6) Adjust RV-8 so that S-meter indicates '9'.

Block diagram

IC 2

PLL Circuit

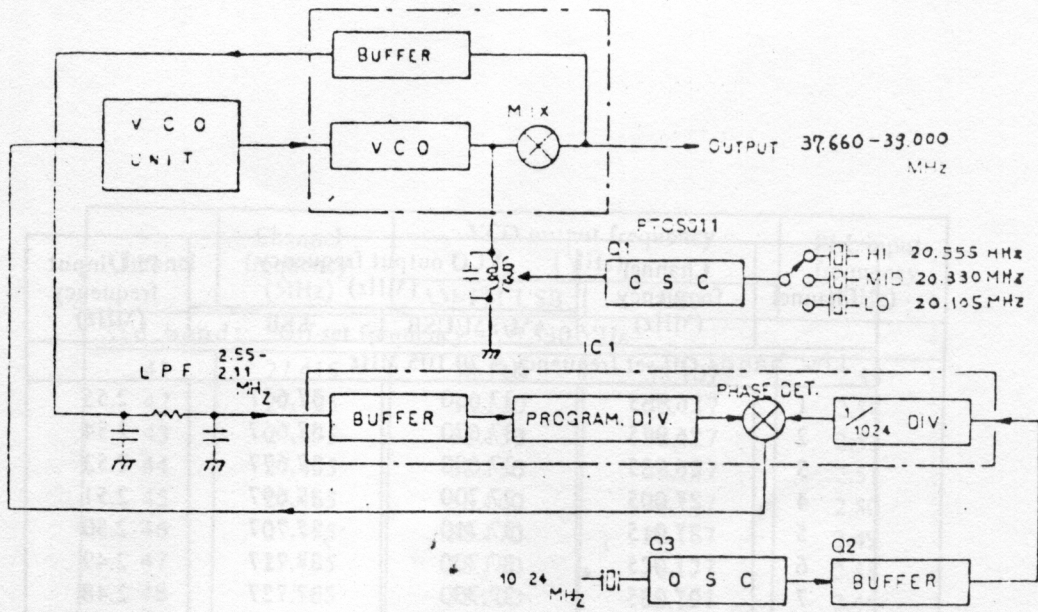

Receiver

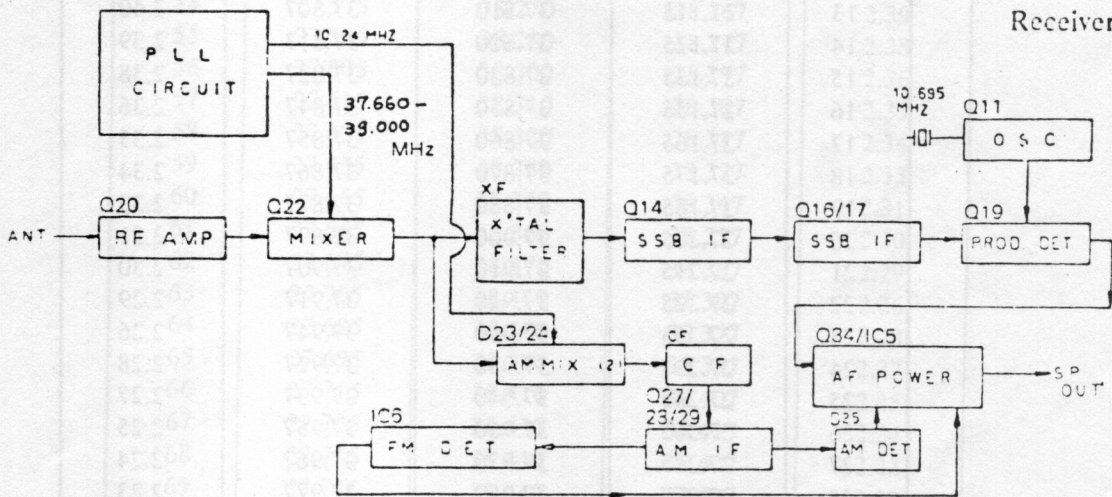

Transmitter

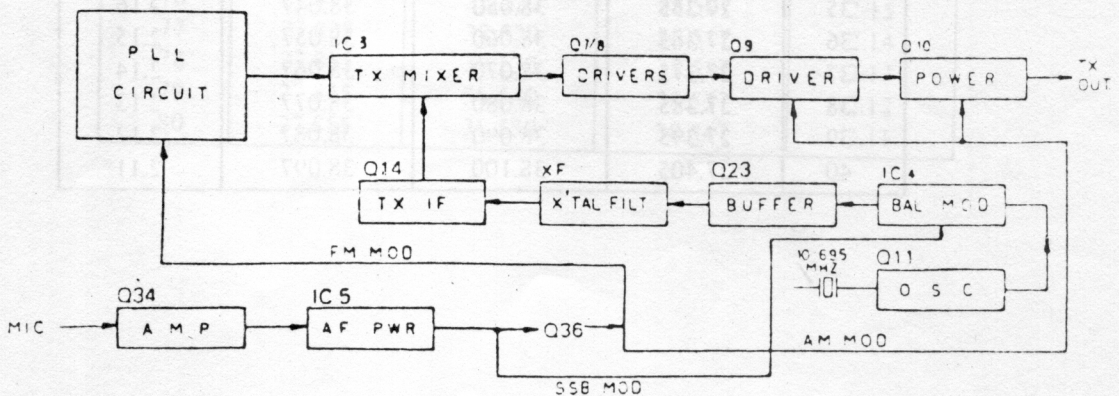

Channel	Channel frequency (MHz)	VCO output frequency (MHz)		PLL input frequency (MHz)
		AM/FM/USB	LSB	
Low band: Off-set frequency = 20.105 MHz				
1	26.965	37.660	37.657	2.55
2	26.975	37.670	37.667	2.54
3	26.985	37.680	37.677	2.53
4	27.005	37.700	37.697	2.51
5	27.015	37.710	37.707	2.50
6	27.025	37.720	37.717	2.49
7	27.035	37.730	37.727	2.48
8	27.055	37.750	37.747	2.46
9	27.065	37.760	37.757	2.45
10	27.075	37.770	37.767	2.44
11	27.085	37.780	37.777	2.43
12	27.105	37.800	37.797	2.41
13	27.115	37.810	37.807	2.40
14	27.125	37.820	37.817	2.39
15	27.135	37.830	37.827	2.38
16	27.155	37.850	37.847	2.36
17	27.165	37.860	37.857	2.35
18	27.175	37.870	37.867	2.34
19	27.185	37.880	37.877	2.33
20	27.205	37.900	37.897	2.31
21	27.215	37.910	37.907	2.30
22	27.225	37.920	37.917	2.29
23	27.255	37.950	37.947	2.26
24	27.235	37.930	37.927	2.28
25	27.245	37.940	37.937	2.27
26	27.265	37.960	37.957	2.25
27	27.275	37.970	37.967	2.24
28	27.285	37.980	37.977	2.23
29	27.295	37.990	37.987	2.22
30	27.305	38.000	37.997	2.21
31	27.315	38.010	38.007	2.20
32	27.325	38.020	38.017	2.19
33	27.335	38.030	38.027	2.18
34	27.345	38.040	38.037	2.17
35	27.355	38.050	38.047	2.16
36	27.365	38.060	38.057	2.15
37	27.375	38.070	38.067	2.14
38	27.385	38.080	38.077	2.13
39	27.395	38.090	38.087	2.12
40	27.405	38.100	38.097	2.11

Channel	Channel frequency (MHz)	VCO output frequency (MHz)		PLL input frequency (MHz)
		AM/FM/USB	LSB	
Mid band: Off-set frequency = 20.330 MHz				
41	27.415	38.110	38.107	2.55
42	27.425	38.120	38.117	2.54
43	27.435	38.130	38.127	2.53
44	27.455	38.150	38.147	2.51
45	27.465	38.160	38.157	2.50
46	27.475	38.170	38.167	2.49
47	27.485	38.180	38.177	2.48
48	27.505	38.200	38.197	2.46
49	27.515	38.210	38.207	2.45
50	27.525	38.220	38.217	2.44
51	27.535	38.230	38.227	2.43
52	27.555	38.250	38.247	2.41
53	27.565	38.260	38.257	2.40
54	27.575	38.270	38.267	2.39
55	27.585	38.280	38.277	2.38
56	27.605	38.300	38.297	2.36
57	27.615	38.310	38.307	2.35
58	27.625	38.320	38.317	2.34
59	27.635	38.330	38.327	2.33
60	27.655	38.350	38.347	2.31
61	27.665	38.360	38.357	2.30
62	27.675	38.370	38.367	2.29
63	27.705	38.400	38.397	2.26
64	27.685	38.380	38.377	2.28
65	27.695	38.390	38.387	2.27
66	27.715	38.410	38.407	2.25
67	27.725	38.420	38.417	2.24
68	27.735	38.430	38.427	2.23
69	27.745	38.440	38.437	2.22
70	27.755	38.450	38.447	2.21
71	27.765	38.460	38.457	2.20
72	27.775	38.470	38.467	2.19
73	27.785	38.480	38.477	2.18
74	27.795	38.490	38.487	2.17
75	27.805	38.500	38.497	2.16
76	27.815	38.510	38.507	2.15
77	27.825	38.520	38.517	2.14
78	27.835	38.530	38.527	2.13
79	27.845	38.540	38.537	2.12
80	27.855	38.550	38.547	2.11

Channel	Channel frequency (MHz)	VCO output frequency (MHz)		PLL input frequency (MHz)
		AM, FM, USB	LSB	
High-band: Off-set frequency = 20.555 MHz				
1	27.865	38.560	38.557	2.55
2	27.875	38.570	38.567	2.54
3	27.885	38.580	38.577	2.53
4	27.905	38.600	38.597	2.51
5	27.915	38.610	38.607	2.50
6	27.925	38.620	38.617	2.49
7	27.935	38.630	38.627	2.48
8	27.955	38.650	38.647	2.46
9	27.965	38.660	38.657	2.45
10	27.975	38.670	38.667	2.44
11	27.985	38.680	38.677	2.43
12	28.005	38.700	38.697	2.41
13	28.015	38.710	38.707	2.40
14	28.025	38.720	38.717	2.39
15	28.035	38.730	38.727	2.38
16	28.055	38.750	38.747	2.36
17	28.065	38.760	38.757	2.35
18	28.075	38.770	38.767	2.34
19	28.085	38.780	38.777	2.33
20	28.105	38.800	38.797	2.31
21	28.115	38.810	38.807	2.30
22	28.125	38.820	38.817	2.29
23	28.155	38.850	38.847	2.26
24	28.135	38.830	38.827	2.28
25	28.145	38.840	38.837	2.27
26	28.165	38.860	38.857	2.25
27	28.175	38.870	38.867	2.24
28	28.185	38.880	38.877	2.23
29	28.195	38.890	38.887	2.22
30	28.205	38.900	38.897	2.21
31	28.215	38.910	38.907	2.20
32	28.225	38.920	38.917	2.19
33	28.235	38.930	38.927	2.18
34	28.245	38.940	38.937	2.17
35	28.255	38.950	38.947	2.16
36	28.265	38.960	38.957	2.15
37	28.275	38.970	38.967	2.14
38	28.285	38.980	38.977	2.13
39	28.295	38.990	38.987	2.12
40	28.305	39.000	38.997	2.11

LED301

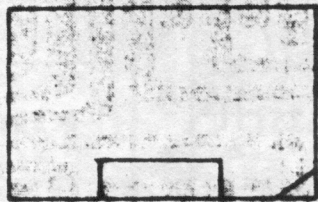

J301

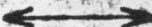

J302

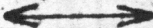

J304

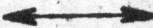

J303

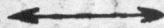

PTLD 043A0X

TP-0N60-HB

▷ 1.25 x 1/4

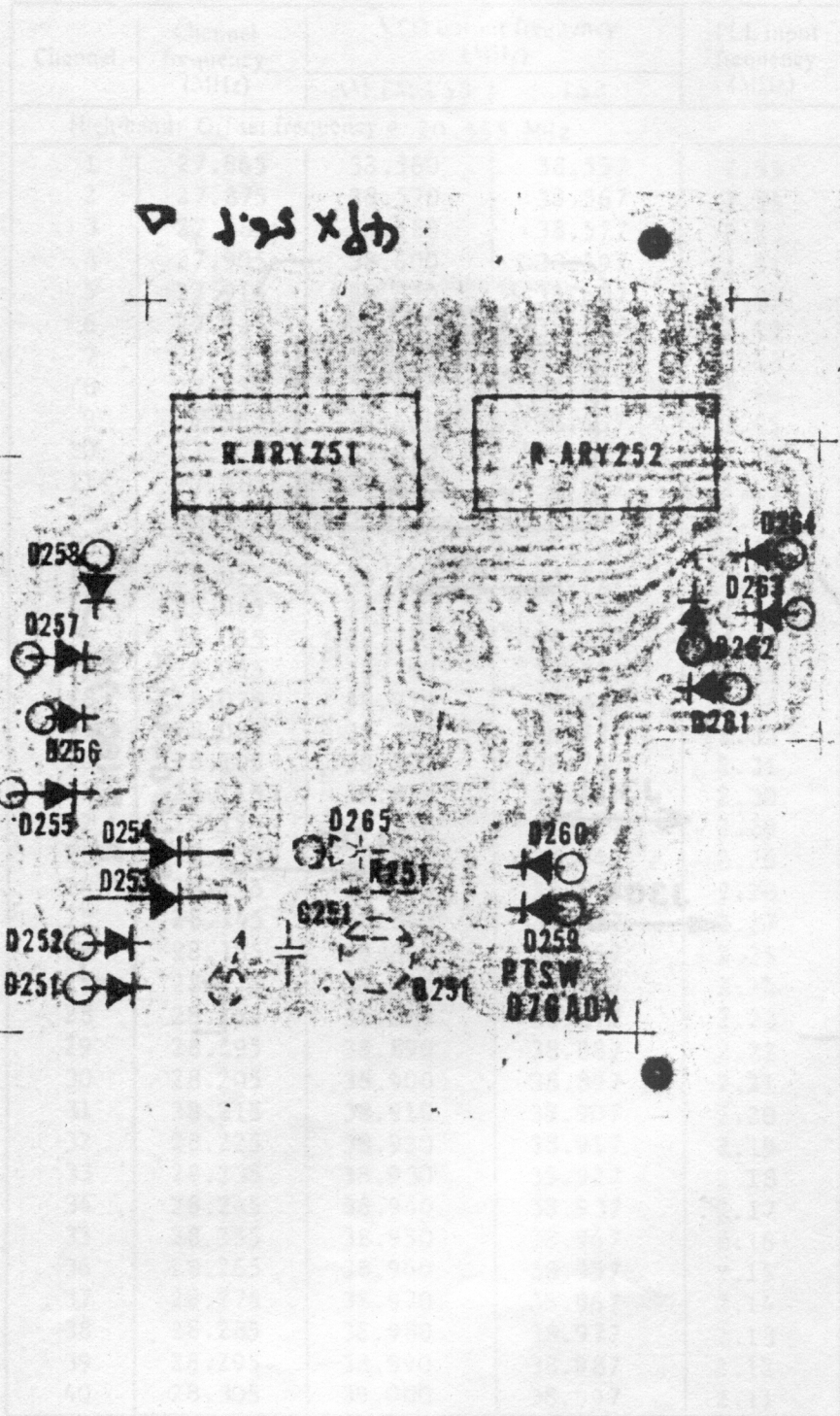

N-ARY251

N-ARY252

D258
D257
B256
D255
D254
D253
D252
B251

D264
D263
D262
B281

D265
R251
C251
B251

D260
D259
PTSW
D76ADK

CONCORDE II

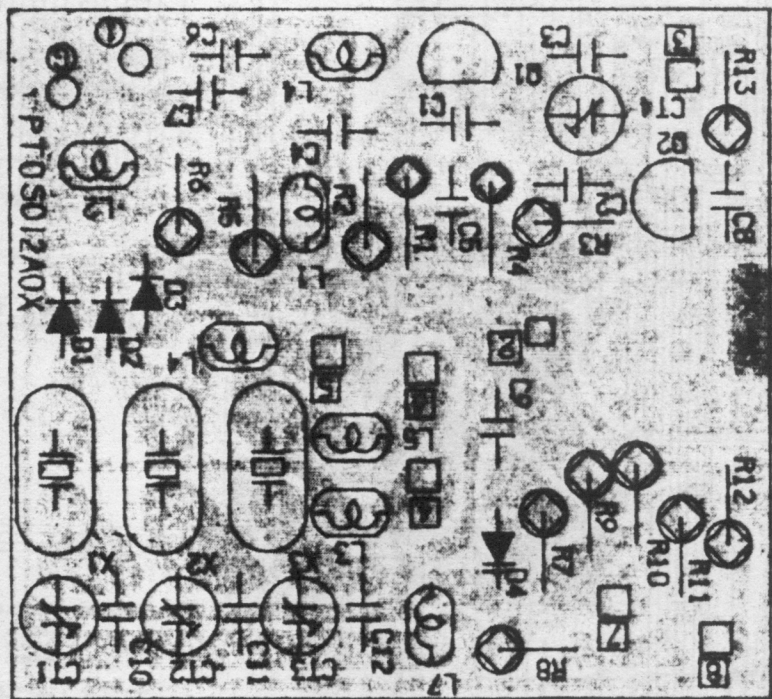

MAN INTERNATIONAL
BORGARNESTRA 10
S-1314 GÖTTINGEN
TEL: (081) 34 72 11
FAX: (081) 34 72 11

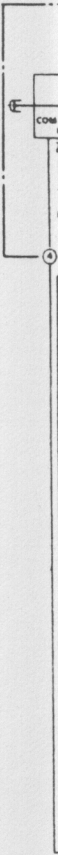
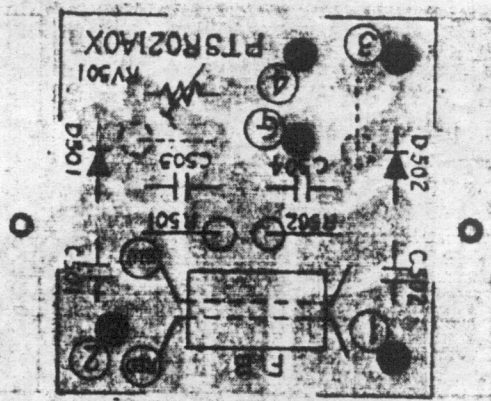

Schematic Diagram

CONCORDE II

NOTE
 ALL VOLTAGES MEASURED FROM PC BOARD GROUND WITH D.C. VTVM AT NO SIGNAL (AT 3.5V POWER SUPPLY)
 IF MEASUREMENT VALUES OBTAINED ARE IN EXCESS OF 20% OF VALUES SHOWN THEN REASON FOR DIFFERENCE SHOULD BE CORRECTED
 A TX. D USE 1.5AM TX
 + CHASSIS GND
 * PC BOARD GND
 * ADJUSTED TYPICAL VALUE SHOWN

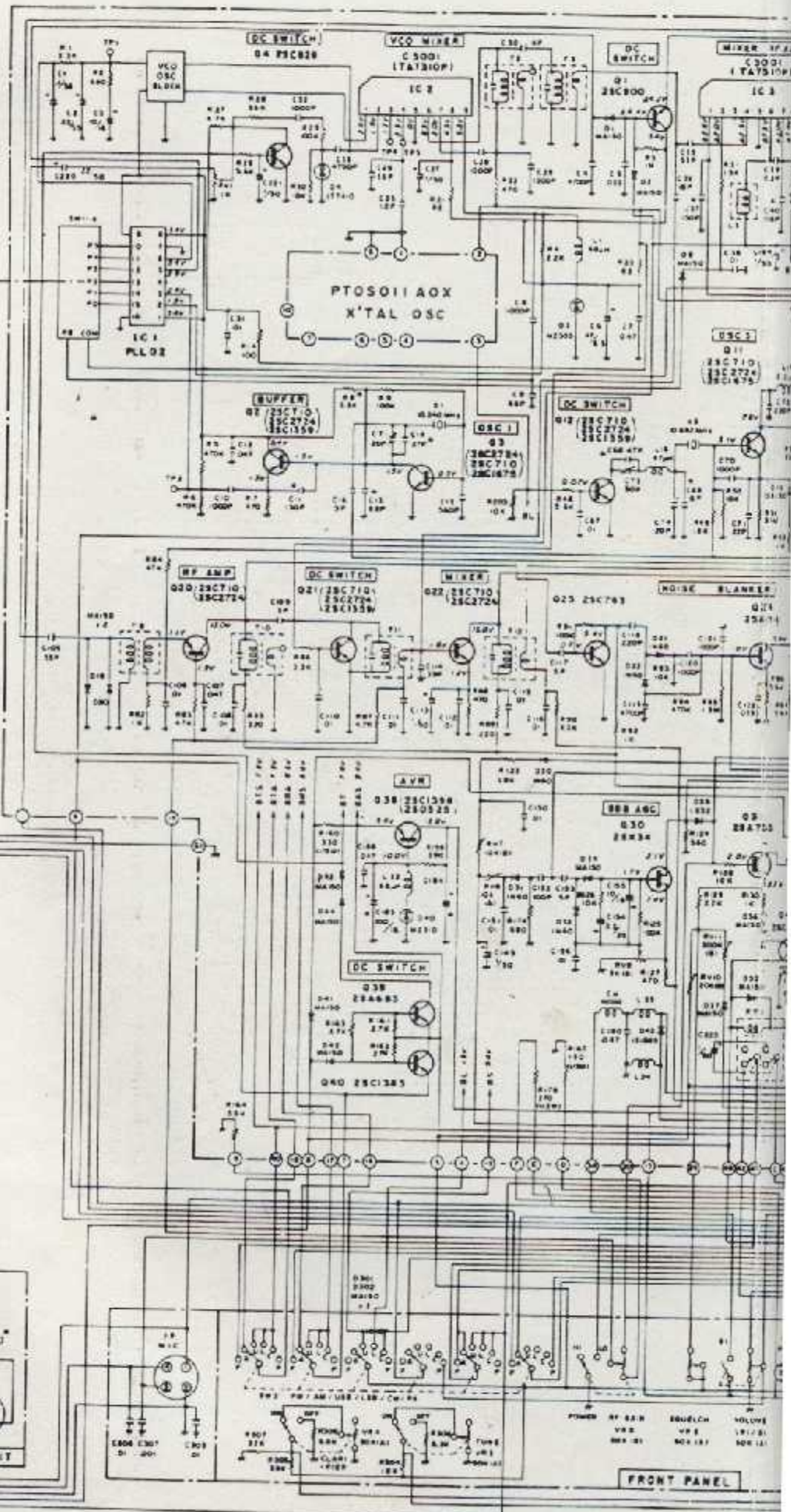
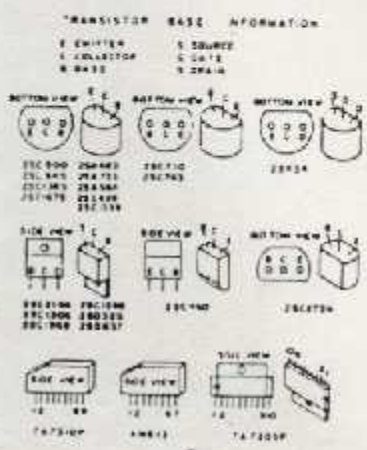
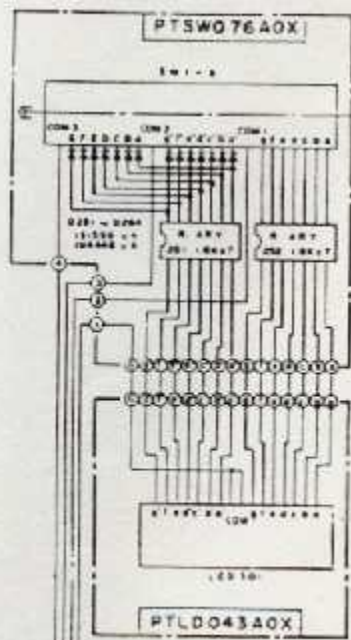

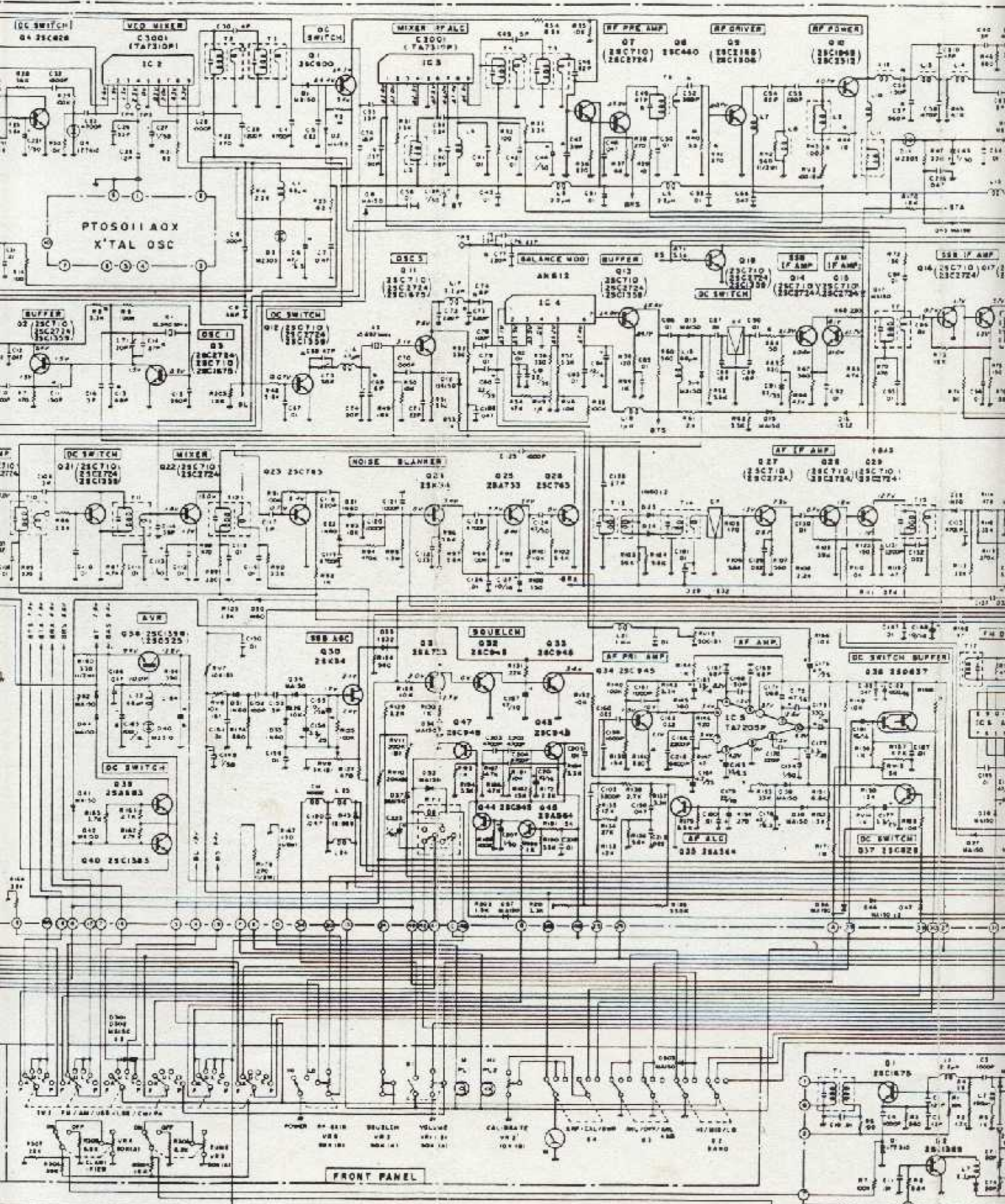

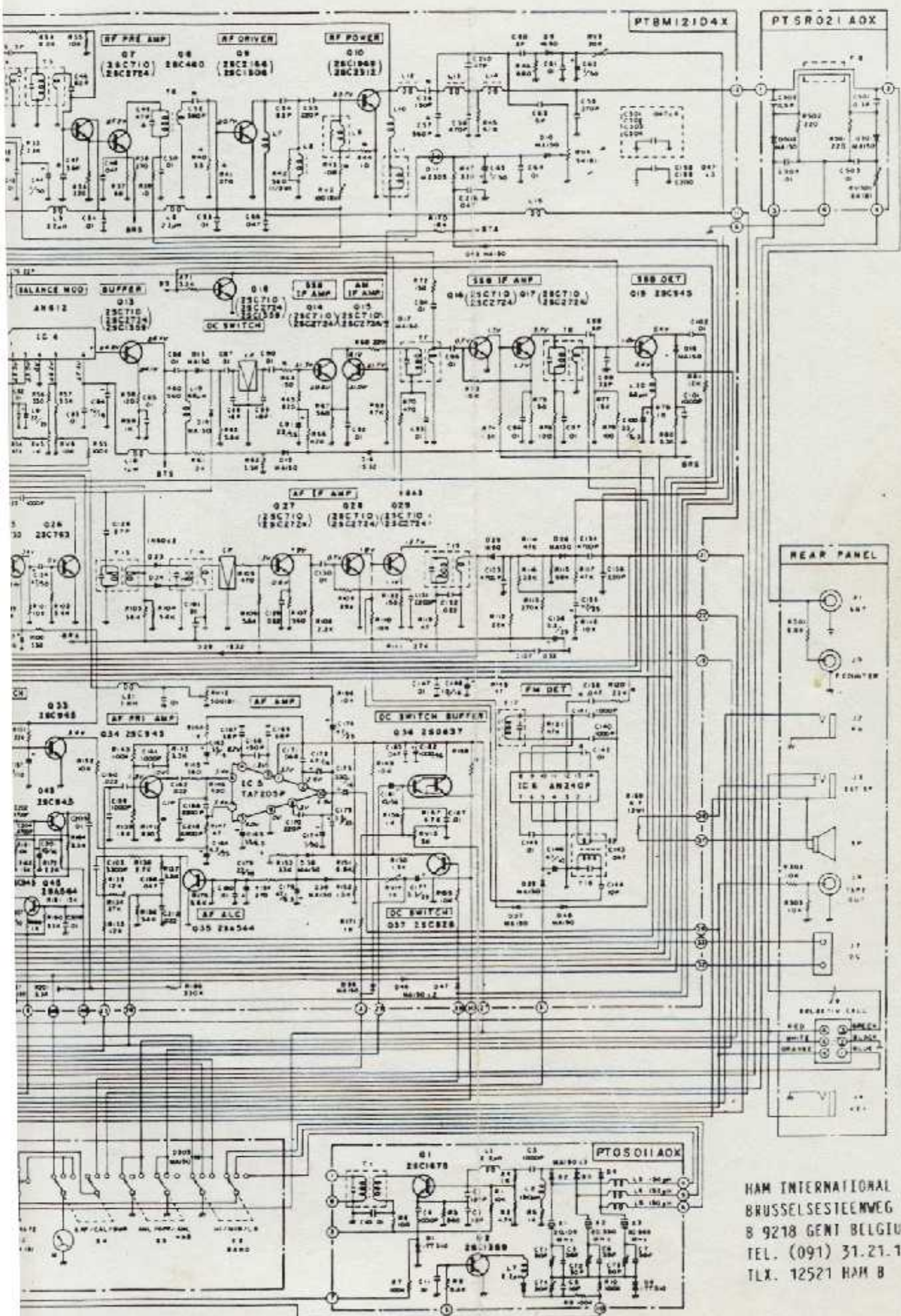

HAM INTERNATIONAL
 BRUSSELESTEEG 428
 B 9218 GENT BELGIUM
 TEL. (091) 31.21.11
 TLX. 12521 HAM B

