



## **GENERAL SPEC**

### **MJ-300 AM/FM MOBIL**

#### **FEATURE**

##### **\* FUNCTION**

1. AM/FM SW
2. SCAN SW
3. CH-9 (RESET) SW  
120CH>>band "LOW>CB>HIGH"
4. UP SW
5. DOWN SW

##### **\* CONTROLS**

1. AF VOLUME CONTROL, W/ ON / OFF SW
2. SQUELCH VOLUME CONTROL

##### **\* LCD DISPLAY**

1. CHANNEL-2DIGIT
2. TX
3. AM/FM
4. SC
5. L , H

##### **\* 3.5 PIE EXT SPEAKER JACK**

##### **\* M-TYPE ANT CONNECTOR**

##### **\* 4 PIN MIC JACK**

C-MIC, PTT SW

##### **\* BILT-IN AUTOMATIC NOISE LIMIT**

##### **\* DIMENSION : W-140mm . D-125mm . H-41mm.**

##### **\* WEIGHT :680 g.(gift total :1200 g)**

## **ELECTRICAL**

### **\* GENERAL**

- @ TRANSMITTER..... CRSTAL CONTROLLED PLL SYNTHESIZER
- @ RECEIVER..... DOUBLE CONVERSION, SUPERHETERODYNE SYSTEM
- @ VOLTAGE OPERATION..... DC 13.8 V
- @ TEMPERATURE..... -10 °C ~ +50 °C
- @ CHANNEL STEP ..... 10 Khz

### **\* TRANSMITTER**

- @ OUTPUT POWER..... FM/AM : 4WATTS  
HP :FM/AM : 6WATTS UP
- @ FREQUENCY RANGE..... 26.965 ~ 27.405 MHz  
LOW BAND :26.515 ~ 26.955 MHz  
CB BAND :26.965 ~ 27.405 MHz  
HI BAND : 27.415 ~ 27.855 MHz
- @ FREQUENCY TOLERANCE..... +-500 Hz
- @ MODULATION SENS..... 10mV(1.25KHz INPUT:C-MIC)
- @ MODULATION CAPABILITY..... AM : 90 %  
FM : 2 KHz

### **\* RECEIVER**

- @ SENSITIVITY..... AM : 0.5 uV(S/N 10dB)  
FM : 0.3 uV (SINAD12dB)

@ SQUELCH..... 1uV MAX  
@ S/N RATIO..... 45 dB  
@ DISTORTION..... 5 %  
@ MAX POWER..... 4 WATTS

**\* TEST CONDITION**

@ POWER SOURCE..... DC 13.8 VOLTS  
@ ANT LOAD IMPEDANCE..... 50 ohm NON-INDUCTIVE  
@ AUDIO LOAD IMPEDANCE..... 8 ohm NON-INDUCTIVE

-----  
 MJ-300 FRONT PCB PART LIST 2006 , 05 ,21 |

-----  
 |Item|Qty |Reference|Part Name |Manufacturer |Description |

Item	Qty	Reference	Part Name	Manufacturer	Description
1	1	C305	C-SMD,0.01B		
2	2	C303-304	C-SMD,0.022B		
3	1	C306	C-SMD,0.1B		
4	1	C307	C-SMD,0.1B		
5	2	C301-302	C-SMD,18PCH		***
6	1	MIC301	4PIN PCB TYPE	W/WASHER,NUT	samwoo
			CONNECTOR		
7	1	D301	D-A,KDS160		
8	1	IC301	IC-44QFP,		samsung CPU
			S3P9228QFP		
9	2	LP301-302	LAMP,14V 40mA		
10	1	LCD301	9 PIN-2.54		SL
11	1	RO3	R-SMD,4.7K		
12	1	R305	R-SMD,100K		
13	4	R302-303	R-SMD,10K		
		R306-307			
14	1	R301	R-SMD,15K		***
15	1	R309	R-SMD,1K		
16	0	RO2	R-SMD,AM OP		
17	0	RO1	R-SMD,FM OP		
18	0	R308	R-SMD,68K		***
19	1	SW301	SW-2P TACT,AM/FM		
20	1	SW304	SW-2P TACT,CH9(RESET)		
21	1	SW303	SW-2P TACT,DOWN		
22	1	SW305	SW-2P TACT,SCAN		
23	1	SW302	SW-2P TACT,UP		
24	1	Q301	TR-A,KRA110S		
25	1	X301	XTL-49/S		
			4MHz:CL18P		
26	1	PCB	FR4 양면		FRONT WHITE

-----

-----  
 |MJ-300 VR PCB PART LIST 2006 , 06 , 21 |

-----  
 |Item|Qty |Reference|Part Name |Manufacturer |Description |  
 |---+---+-----+-----+-----+-----|  
1	1	SQ301	VR-9PIE ,10KB	20MM SHAFT	
2	1	VR301	VR-9PIE ,50KA	20MM SHAFT	
3	1	VR PCB	FR4 double		
 -----

-----  
 |MJ-300 MIC ASSY 2005 , 08 , 21 |

-----  
 |Item|Qty |Reference|Part Name |Manufacturer |Description |  
 |---+---+-----+-----+-----+-----|  
1	1	MIC PLUG	4PIN		W/SCREW,MT ASSY
2	1	CURL CORD	3P 1SHIELD	4PIE/ 2M	
3	1	PTT SW	2C-2P NON LOCK		
4	1	MIC PCB	FR4 양면		MOBIL 공용
12	1	C-MIC	9.7 X 5	44dB SOLDER	1.5V
 -----

# MJ-300 THEORY OF CIRCUITS , ALIGNMENT PROCEDURES

## 1. CIRCUIT DESCRIPTION

### 1-1. PLL PARTY

Main CPU IC does Kondeurol to serial data to PLL IC doing function and Display indication function at the same time.

VCO AND REFERENCE FREQUENCY OSCILRATE AND THE PHASE DETECTER HAVE DESIGNATED PLL CIRCUIT, WHICH PHASE BOTH FREQUENCIES.

THE OUTPUT OF PHASE DETECTOR CONTROLLED VCO AND MAKE STABLIZED OF VCO OSCILATE FRQUENCY.  
THE PLL WILL WORKING STABLY WHEN THE PHASE OF VCO AND REFERENCE FREQUENCY SHOULD BE EQUAL.

### PLL BLOCK DIAGRAM

→ REFERENCE FREQUENCY ---→  
→ VCO. OSCILLATOR ---→  
→ PHASE COMPARATOR → L.P.F → TO VCO OSC.  
(LOW PASS FILTER)

## 1-2. RECEIVER PARTY

### 1-2-1. HIGH FREQUENCY AMPLIFICATION PARTY.

Q2 IS HIGH FREQUENCY AMPLIFICATION TRANSISTOR AND APPLIED COMMON EMITTER METHOD.

THIS CIRCUIT HAS BEEN FEATURED AS HIGH SENSITIVITY AND LOW NOISE.

D6 IS WORKING AS WHEN INCOMING STRONG SIGNAL ON RECEIVER.

### 1-2-2. FIRST MIXER PARTY

Q8,Q9 IS MIXER PARTY. AND IT HAS OUTPUT 10.700MHz(MID RANGE) BY MIXE HIGH FREQUENCY AMPLIFICATED SIGANL AND 1ST LOCAL OSCILLATED FREQUENCY.

FOR EXAMPLE, IF THIS EQUIPMENT IS 19CH, THE FREQUENCY IS 27.185MHz AND 1ST LOCAL FREQUENCY IS 16.485MHz.

SO,  $F_o$  - 1ST LOCAL FREQUENCY (V.C.O FREQ.) ARE 10.700MHz.

### 1-2-3. FILTER APRTY

WHEN THE 10.700MHz WHICH MADE FROM THE FIRST MIXER PARTY PASSED CF1,2 FILTER GETS REAL 10.700MHz SIGNAL WHICH HAS BAND WIDTH  $\pm 7.5$ kHz.

### 1-2-4. 2ND MIXER PARTY

WHEN THE 10.700MHz AND 2ND LOCAL FREQUENCY (10.245MHz) ARE MIXED BY IC 1, THE MIDDLE FREQUENCY 455kHz HAS OUTPUTED AND PASSING CF3 FILTER.

1-2-5. FM DETECTOR PARTY.

THE FM SIGNAL DETECTING BY IC 1 AND TURN TO VOICE  
SIGNAL ON D12(SWITCH ).

1-2-6. AM FREQUENCY DETECTOR PARTY

The AM detecting waves amplifies 455 KHzs sign that appear in FM DET IC  
in Q10, Q11, Boiseu signal that is detected by D11 is sent to D12(SWITCH ).

1-2-7. AUDIO AMPLIFIER PARTY

MODIFIED VOICE SIGNAL WILL BE HEARED TROUGH SPEAKER  
BY PASSING VOLUME AND AUDIO POWER AMP (IC 5).

RECEIVER BLOCK DIAGRAM



## RX BLOCK DIAGRAM

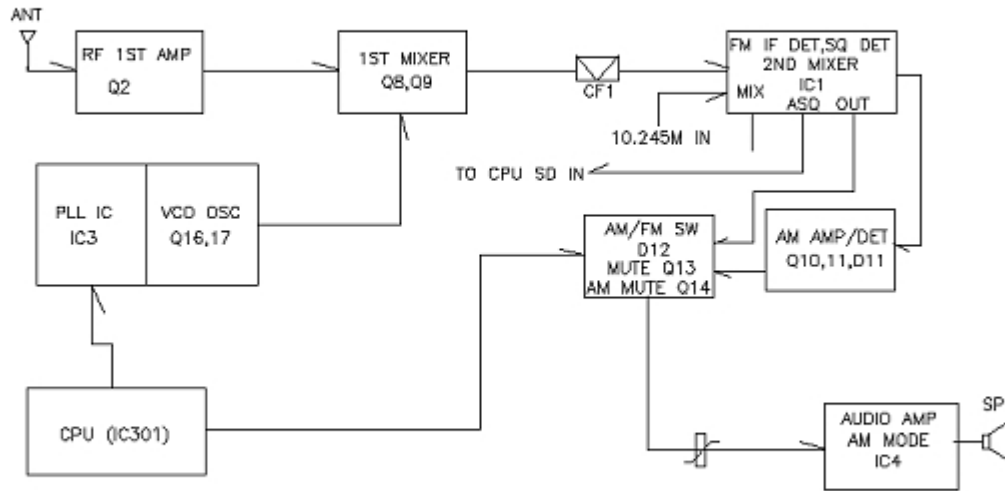

### 1-3. TRANSMITTER PARTY.

#### 1-3-1. V.C.O PARTY (VOLTAGE CONTROL OSCILLATOR)

ACCORDING TO VCO VOLTAGE MODIFIED OF EACH CHANNEL,  
 $FVCO \times 2$  FREQUENCY \*(IN CASE IF 19CH, 27.185MHz) IS MADE  
 BY VCO FREQUENCY & DIVIDE RATIO (N) ARE MODIFYING.

AT THIS TIME, THE VCO FREQ (13.5925MHz AT 19CH) IS FLOW IN Q30.  
 AND ON Q30, DOUBLER THE FVCO  $\times 2$  MHz IS TURN TO 27.185MHz  
 FLOW IN Q31 BSAE.

THE Q31 ARE PRE-AMPLIFIER. AND IT AMPLIFICATE WEAK CARRIER  
 OF 27.185MHz. THE 27.185MHz FLOW IN TO Q32 AND IT AMPLIFICATE  
 ON THE Q33 (TX POWER AMP) AND RADIATE BY ANTENNA THROUGH L.P.F.

#### 1-3-2. L.P.F (LOW PASS FILTER)

L5, L6, L7, L8, L9, L10 & C26, C27, C94, C95, C96, C97, C98 ARE L.P.F CIRCUIT.  
 54MHz TRAP L11, C100. AND THIS CIRCUIT DEPRESS THE NEEDLESS HARMONICS TO  
 UNDER 90dB EXCEPT THE 27MHz.

1-3-4. AM MODULATION

- A) THE AMPLIFICATED SIGNAL ON IC5(1/2) FLOW IN TO IC4. AND THIS SIGNAL MODULATED ON IC4, OPT1 THROUGH D24.
- B) AMC CONTROLLED BY Q28 AFTER DETECT ON Q29,D15.

1-3-5. FM MODULATION

THE AMPLIFICATED SIGNAL ON IC5(1/2) FLOW IN TO LIMIT DIODE D6 AND LPF IC5(2/2) FLOW IN TO MODULATED UNDER CONTROL OF FVCO WHICH MODIFIDE VARIABLE CAPACITOR D14 THROUGH FILTER.

TX BLOCK DIAGRAM

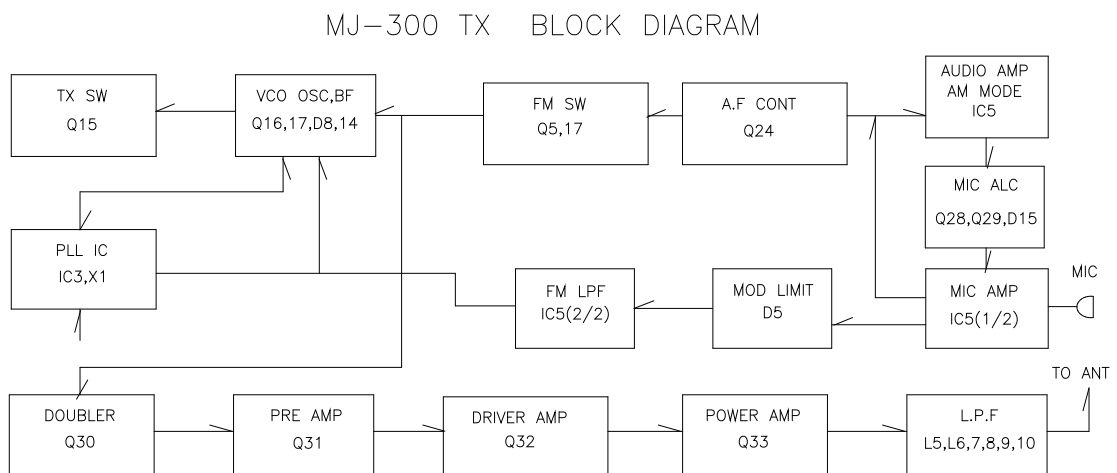

## **2. HOW TO ADJUST**

### **2-1. PREPARATION**

#### **2-1-1. HOW TO DISASSEMBLE**

TAKE OFF 8 PCS OF SCREWS ON SDIE PART OF BOTTOM COVER.

### **2-2. ADJUST & TEST POINT**

PARTS LOCATION DIAGRAM

## MJ-300 EU PARTS LOCATION

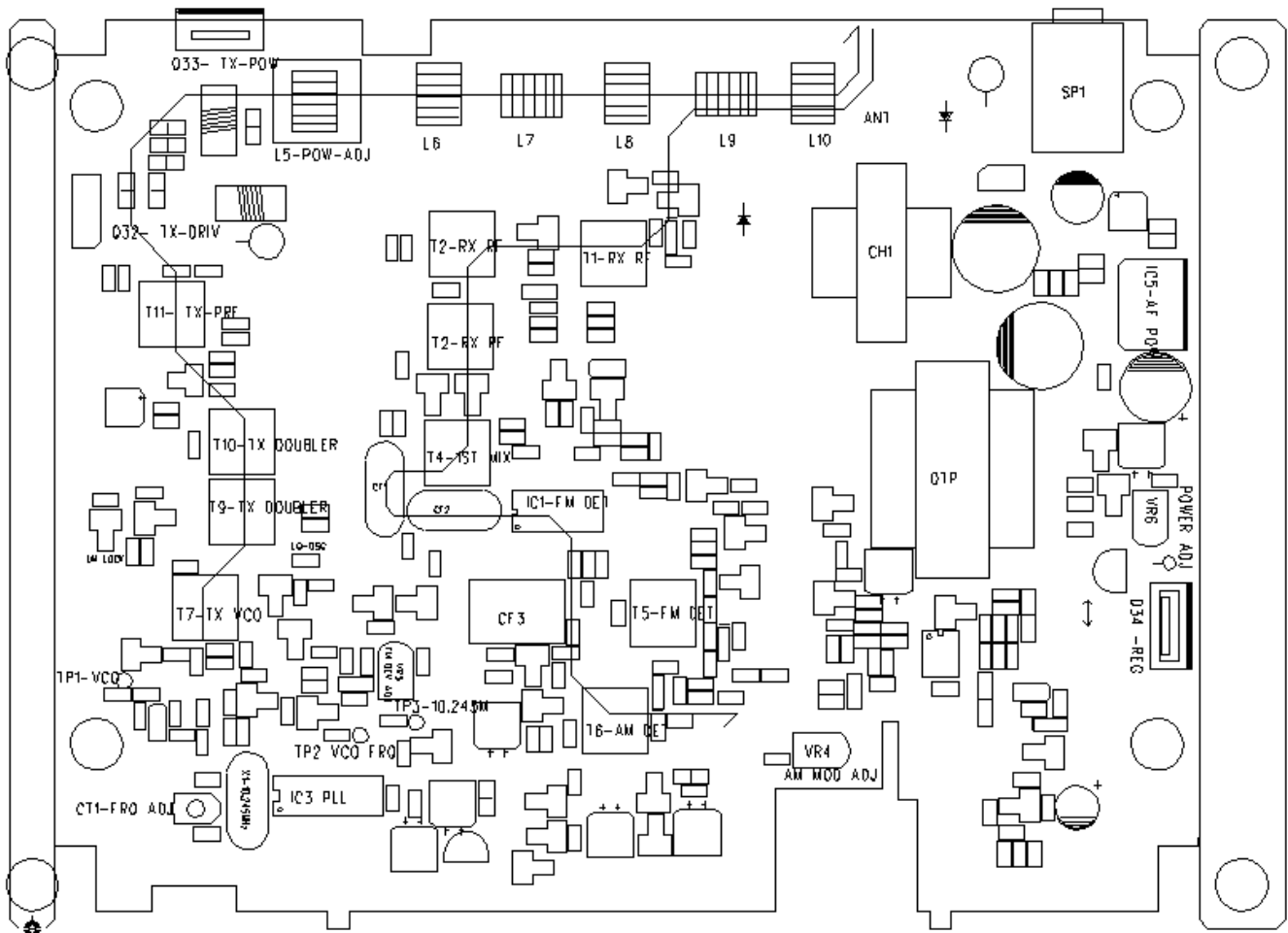

### 2-3. PASHE LOCKED LOOP & VCO PARTY

#### A) TEST EQUIPMENTS

- 1) FREQUENCY COUNTER
- 2) D.C POWER SUPPLY (13.8 VOLT. 3 Amp)

3) DC VOLTMETER

4) OSCILLOSCOPE

B) ADJUST ORDER

ORDER	PREPARATION	CONNECTION	POINT	ADJUST
1	10.245MHz ADJUST 1) PTT S/W : RX 2) VR/SQ : TX 3) CH : FM 1CH	CONNECT ON TP3 WITH PROBE AND CHECK THE FREQ COUNTER	CT1	10.245MHz +/- 100Hz
2	RX VCO ADJUST 1) PTT S/W : RX 2) VR/SQ : MORMAL 3) CH : FM 1CH	CONNECT ON DC VOLTMETER TO TP1	T7	2.5V
3	TX VCO CHECK 1) PTT S/W : TX 2) VR/SQ : NORMAL 3) CH : FM 1CH	SAME AS ABOVE	T7	2.5~3.0V
4	F VCO CHECK 1) PTT S/W : RX 2) VR/SQ : NORMAL 3) CH : FM 1CH	CONNECT ON PROBE TO TP2.  FREQ.COUNTER		16.2625MHz

### VCO TEST DIAGRAM

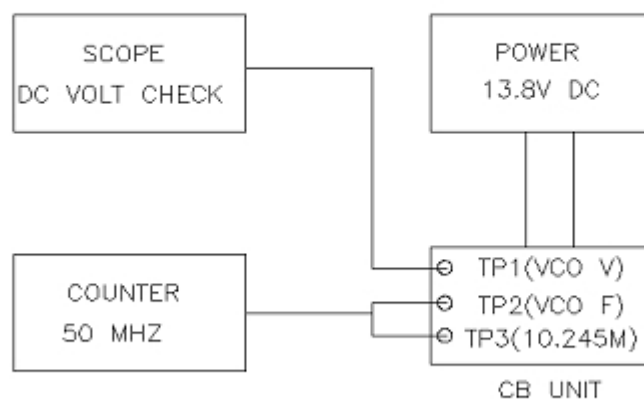

## 2-4. TRANSMITTER PARTY

### A) TEST INSTRUMENTS

- 1) RF POWER METER
- 2) 50 ohm LOAD
- 3) RF ATTENUATOR
- 4) OSCILOSCOPE
- 5) AUDIO GENERATOR
- 6) DC POWER METER (13.8V 3A)
- 7) SPECTRUM ANALYZER
- 8) FREQUENCY COUNTER
- 9) COUPER
- 10) DUMMY LOAD
- 11) MODULATION METER

### B) CONTROL ORDER

No	PREPARATION	CONNECTION	POINT	ADJUST
1	RF DRIVER & CURRENT ADJUST 1) PTT S/W : TX 2) VR/SQ : NORMAL 3) MODE: AM 4) CH : 19CH	ADASHIVE 50ohm DUMMY LOAD ON RF POWER METER AND CONNECT ON ANTENNA JACK ON EQUIPMENT. TX TEST2	*T9,T10,,T11, L1, TK1 (AM:NO MOD)	*CONTROL UPTO MAXIM -UM RF DRIVER LEVEL MAXIMUM OUTPUT
2	ADJUST RF POWER 1)PTT S/W : TX MODE 2)VR/SQ : NORMAL 3)MODE:AM 4)CH : 19CH	SAME AS ABOVE	*FM/AM:VR6	*ADJUST 4WATTS
3	2ND HRAMONIC CONFIR- MATION 1) PTT S/W:TX MODE 2) VOLUME: NORMAL 3) SQUELCH : NORMAL 4) CH: AM 19CH	CONNET THE RF ATTENUATOR(-90dB) TO ANT JACK OF EQUIP AND CONNECT TO SPECTRUM. TX TEST2		CONFIRMATION DISPLAYED BASIC FRE -QUENCY AND 2ND,3RD FREQ.UNDER NONMOD -ULATE CONDITION

№	PREPARATION	CONNECTION	POINT	ADJUST
4	TX FREQUENCY CONFIRMATION 1) PTT S/W: TX MODE 2) VOLUME: NORMAL 3) SQUELCH: NORMAL 4) CH: AM 19CH	CONNECT FREQUENCY COUNTER TO ON OUTPUT OF DUMMY LOAD. TX TEST1	CT1	ADJUST FREQUENCY AS 27.185MHZ +/-200HZ WHICH DISPLAY ON FREQ. COUNTER
5	AM MODULATION CONFIRMATION 1) PTT S/W : TX MODE 2) VOLUME : NORMAL 3) SQUELCH : NORMAL 4) CH : 19CH 5) MODE S/W : AM	CONNECT THE OUTPUT TO OSCILOSCOPE. INSERT TO 1KHZ SIGNAL OF AUDIO GENERATOR TO BOTH TERMINAL OF MIC OF SET.TX TEST1	VR4	ADJUST 85~ 90% MODULATE ON OSCILOSCOPE IN MODULATION SITUATION.
6	FM MODULATION CONFIRMATION 1) PTT S/W : TX MODE 2) VOLUME : NORMAL 3) SQUELCH : NORMAL 4) CH : 19CH 5) MODE S/W : FM	CONNECT THE RF OUT POWER METER TO DEV METER. INSERT THE 1.25KHZ 20mV SIGNAL OF AUDIO GENERATOR TO BOTH TERMINAL OF MIC OF SET. TX TEST1	VR3	ADJUST 2.0KHZ ON DEV.METER UNDER CONDITION OF MODULATION.





## TX TEST DIAGRAM 1

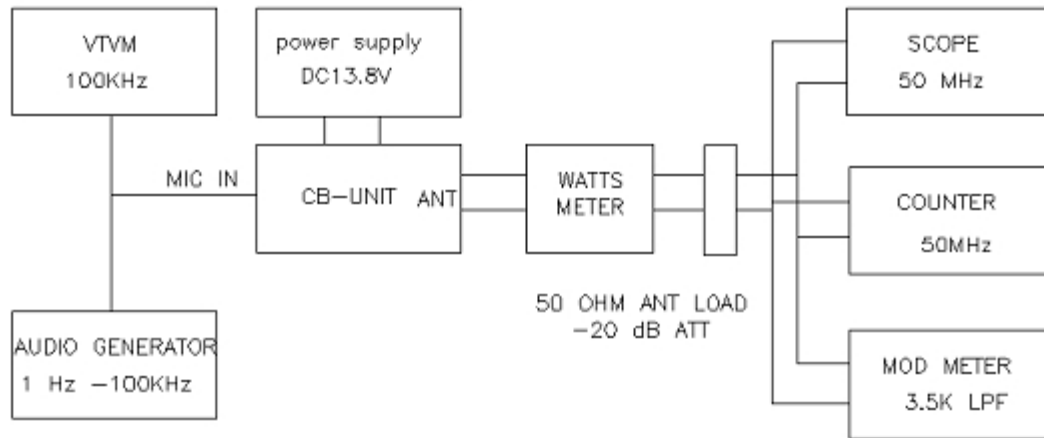

## TX TEST DIAGRAM 2

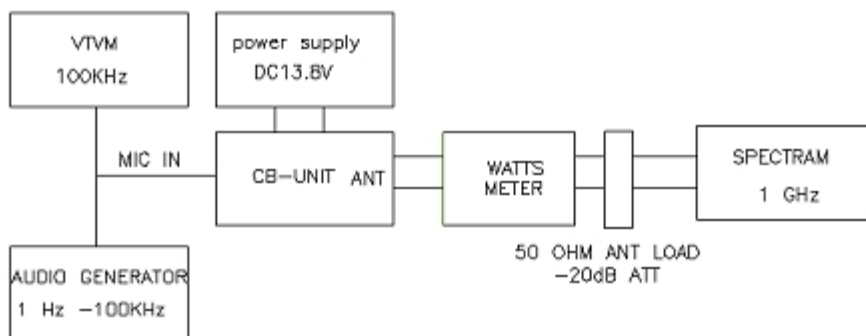

## 2-5 RECEIVER PARTY

### A) TEST EQUIPMENTS

- 1) S.S.G
- 2) V.T.V.M
- 3) DISTORTION METER
- 4) DC POWER SUPPLY
- 5) 8 ohm DUMMY LOAD

### B) ADJUST ORDER

NO	PREPARATION	CONNECTION	POINT	ADJUST
1	RF DRIVER/ 1F PARTY 1) PTT S/W : RX MODE 2) VOLUME : MINIMUM 3) SQUELCH : MINIMUM 4) CH : 19CH 5) S.S.G : 27.185MHZ 1KHZ. ATT 30% MODE 6) MODE S/W : AM	CONNECT SSG TO ANT JACK AND CONNECT VTVM & DISTORTION METER TO 8ohm. RX TEST	T1,T2,T3,T4, T6.	ADJUST VTVM TO MAXIMUM
2	FM/DET PARTY 1) PTT S/W : RX MODE 2) VOLUME : STANDARD 3) SQUELCH : MINIMUM 4) CHANNEL : 19 CH 5) S.S.G : 27.185MHZ 1 KHZ, 1mV, 1.25 KHZ, DEV 6) MODE S/W : FM	SAME AS ABOVE RX TEST	T5	SAME AS ABOVE
3	SQ ACTIVITY SITUATION 1) PTT S/W : RX MODE 2) VOLUME : STANDARD 3) SQUELCH : MAXIMUM 4) CH : 19 CH 5) S.S.G : 27.185MHZ ATT0.5~1uV	INSERT THE SSG TO ANT JACK AND CONNECT VTVM & DISTORTION METER TO 8 ohm LOAD. RX TEST	-	SQ VR MAXIMUM ADJUST UNTILL LOW FREQUENCY 1KHZ WILL APPEAR.

1 KHZ 30% MOD 6) MODE S/W : AM			
-----------------------------------	--	--	--

RX TEST DIAGRAM

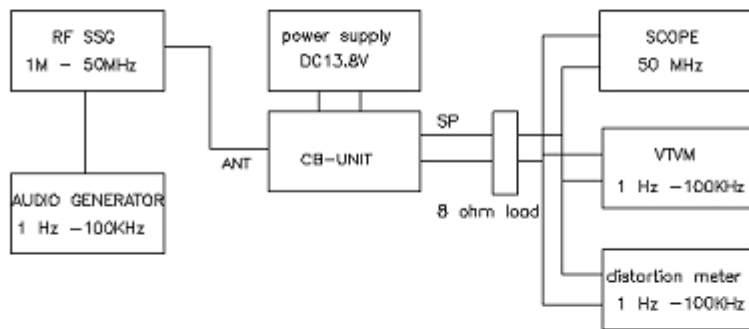



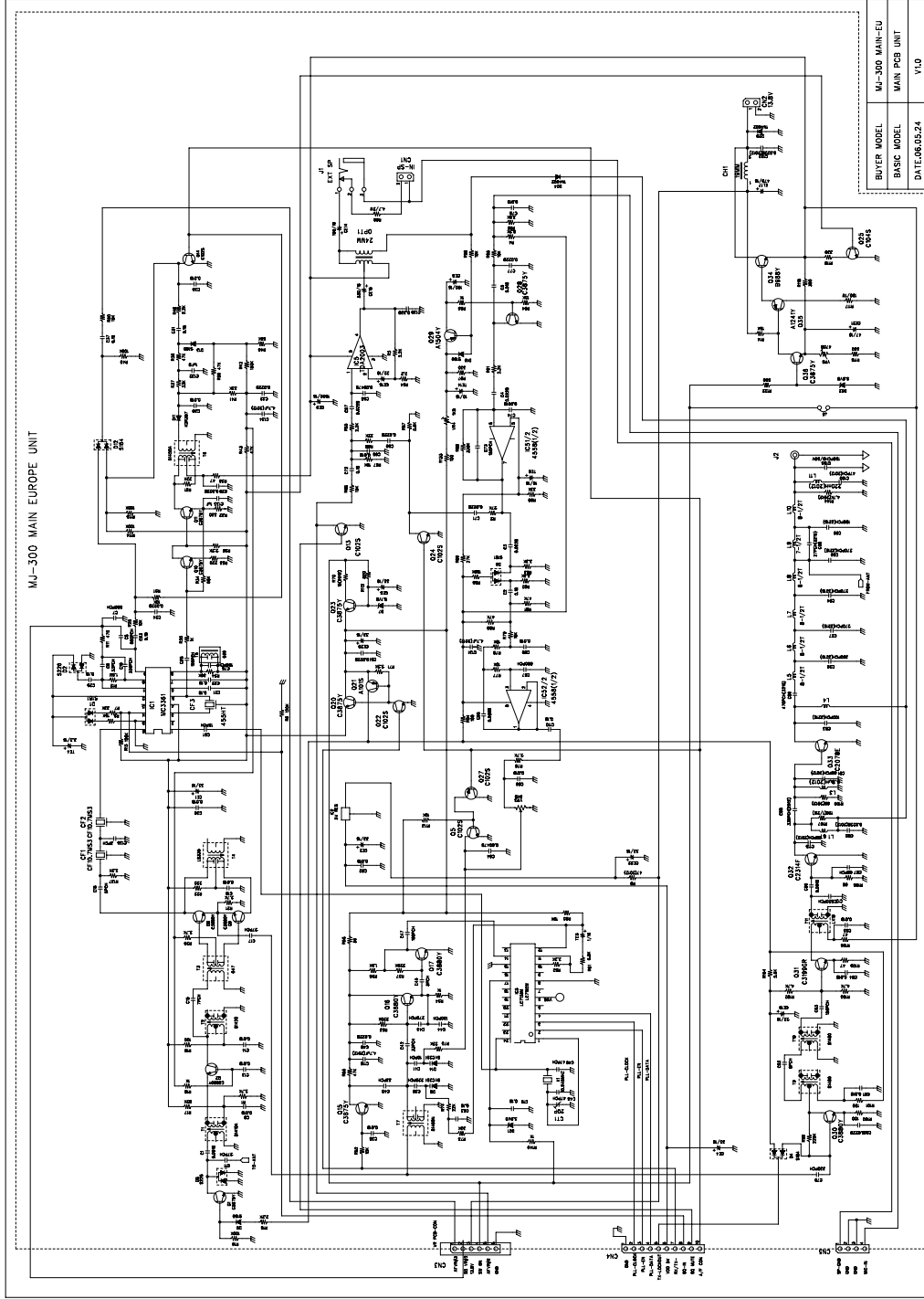

MJ-300 MAIN EUROPE UNIT

BUYER MODEL	MJ-300 MAIN-EU
BASIC MODEL	MAIN PCB UNIT
DATE	06.05.24
Y.U.O	

# MJ-300 EU PARTS LOCATION

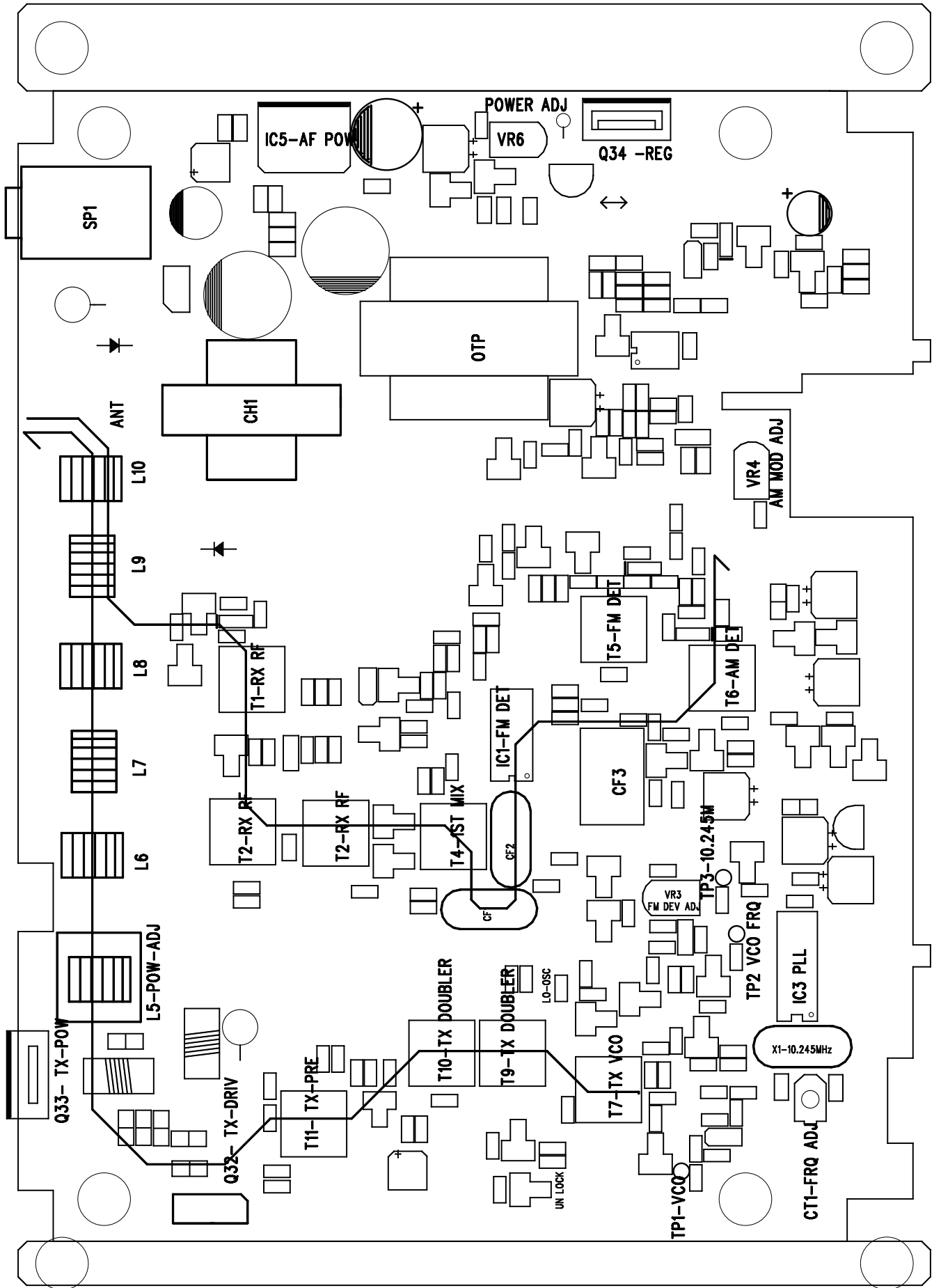







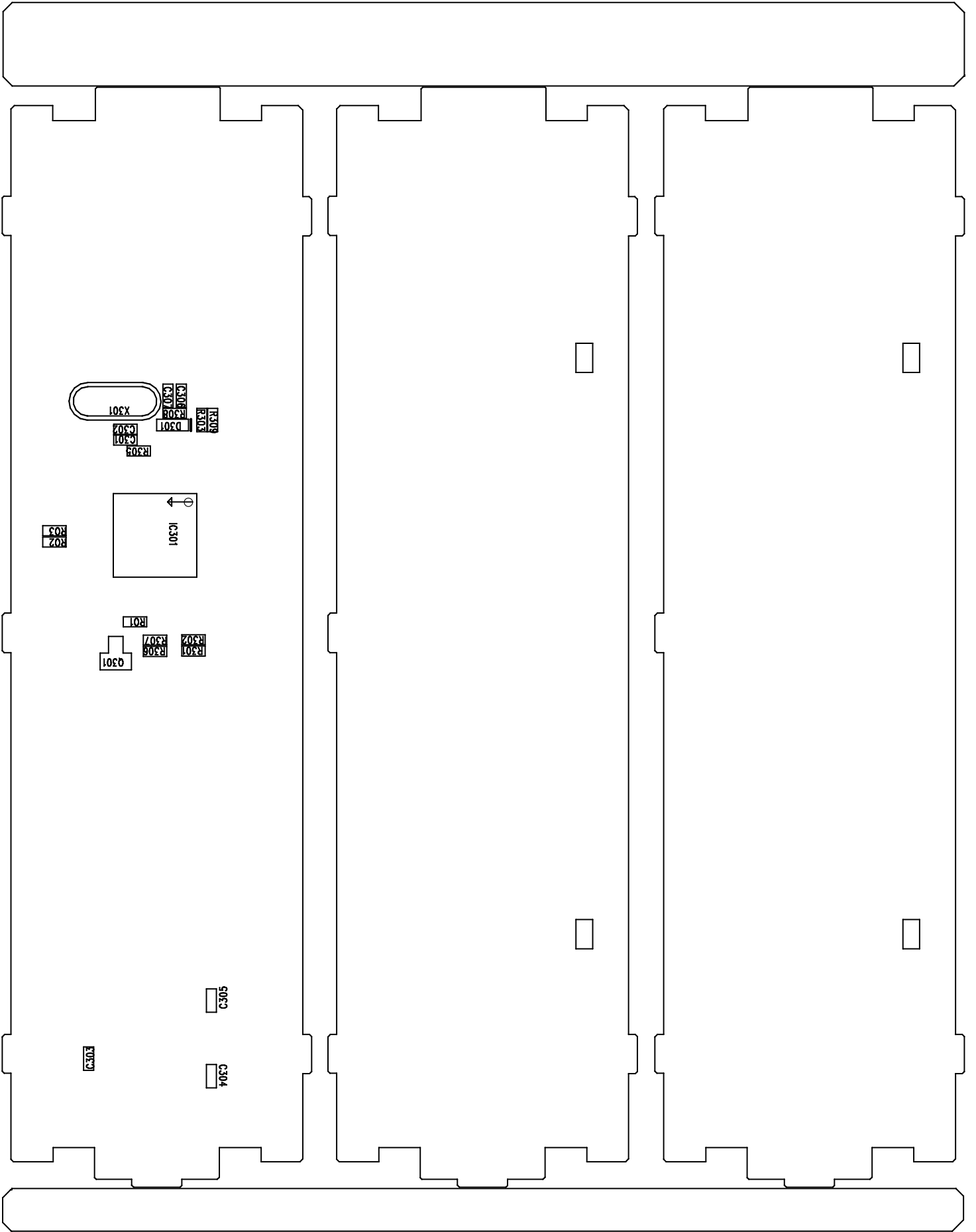

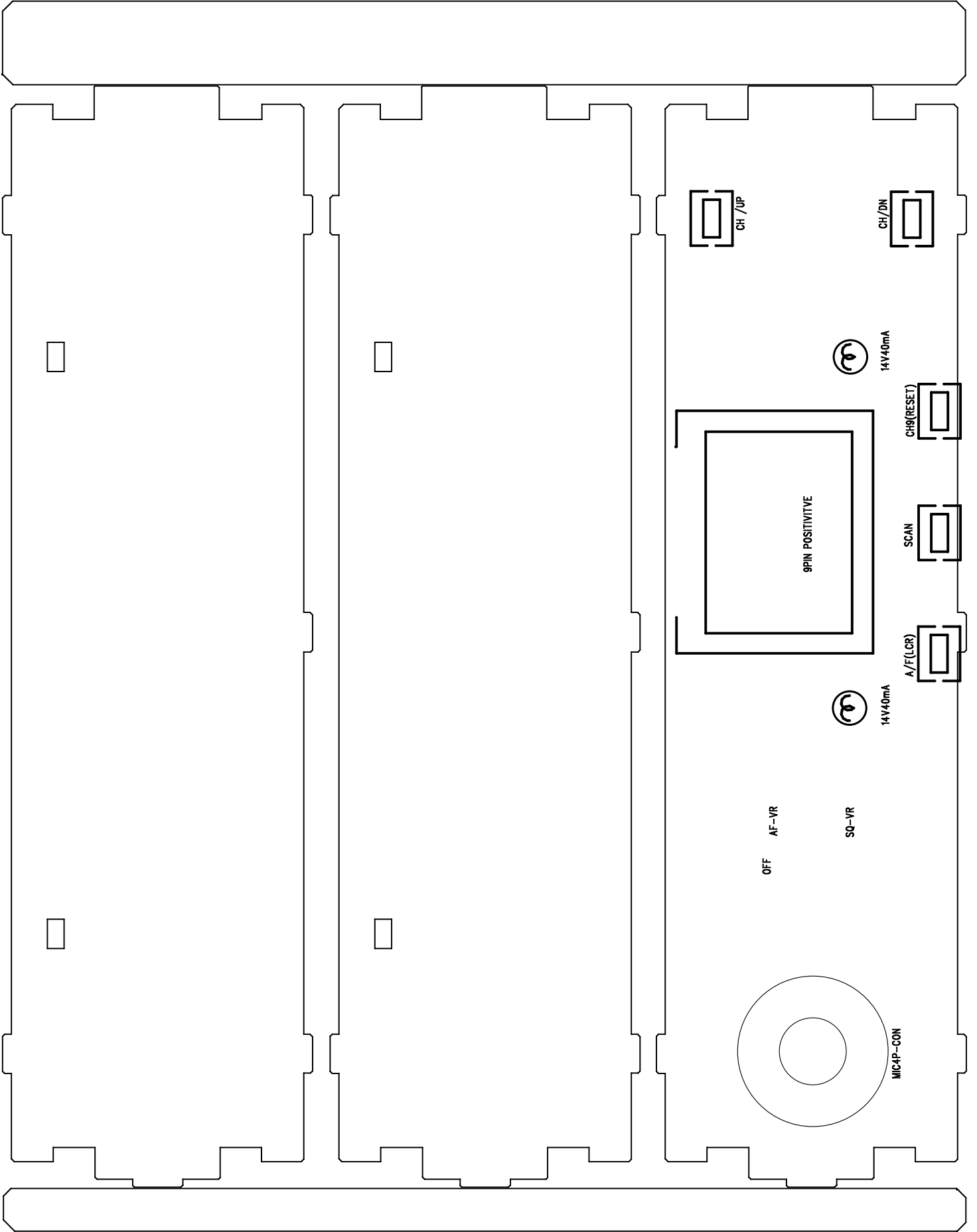

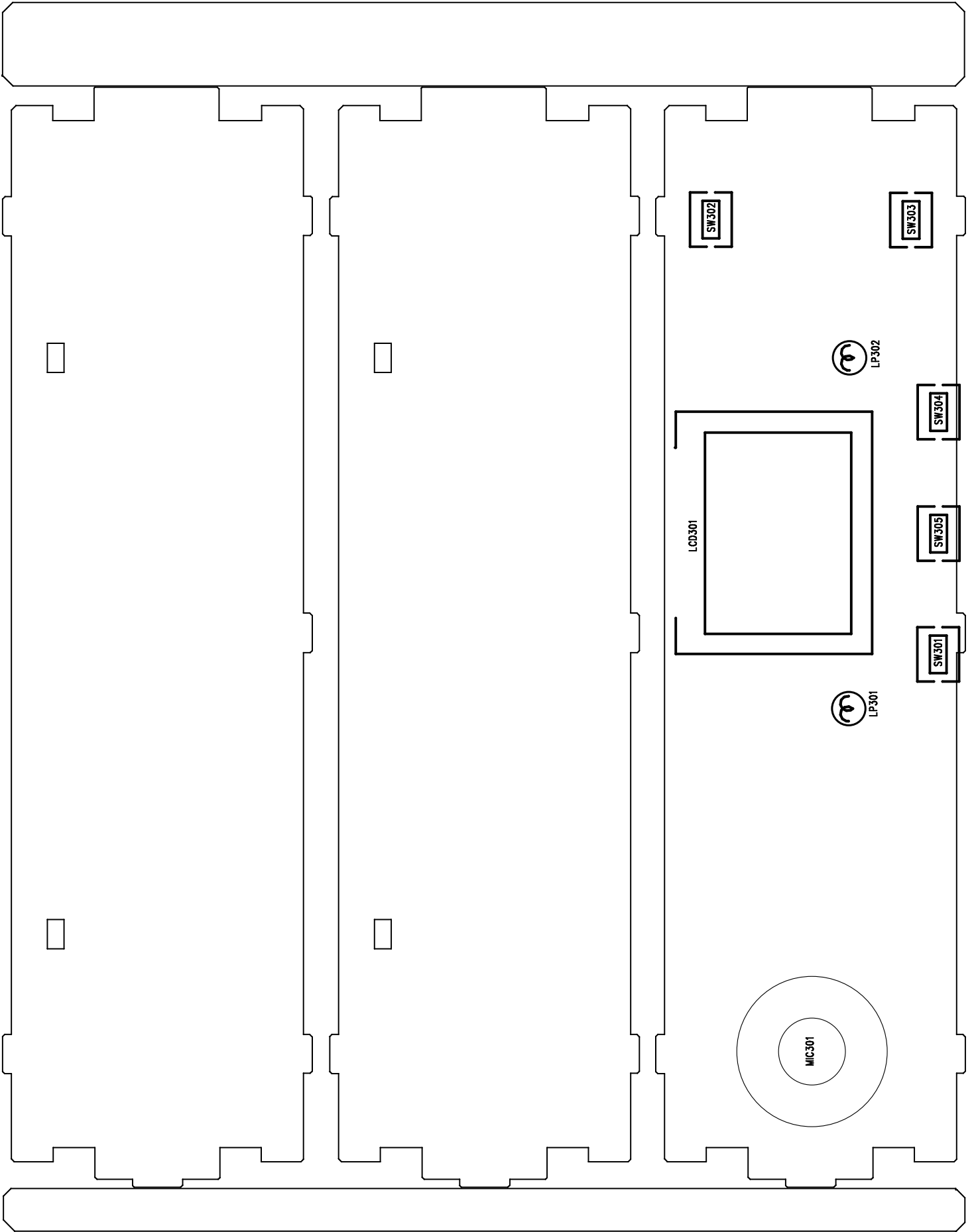

MJ-300 MAIN PCB PART LIST

May 26 12:35:15 2006

Item	Qty	Reference	Part Name	Manufacturer	Description
1	1	J2	ANT,ANT		
2	3	C1 C74	C-SMD,0.001B		
		C86			
3	2	C56 C64	C-SMD,0.0047B		
4	17	C5 C8	C-SMD,0.01B		
		C13-14			
		C16 C30			
		C35-36			
		C38 C62			
		C65-66			
		C69 C78			
		C81			
		C84-85			
5	12	C3-4 C24	C-SMD,0.022B		
		C29 C32			
		C46 C57			
		C59 C61			
		C71 C77			
		C80			
6	2	C90 C102	C-SMD, 0.022B(2012)		
7	1	C68	C-SMD,0.068B		
8	11	C2 C19	C-SMD,0.1B		
		C21-23			
		C25 C31			
		C37 C63			
		C72 C110			
9	1	C130	C-SMD,0.33B		
10	2	C28 C47	C-SMD,100PCH		
11	1	C93	C-SMD, 100PCH(3216)		
12	1	C41	C-SMD,10PCH		

13	3	C44 C73	C-SMD,150PCH			
		C83				
14	1	C103	C-SMD,			
			150PCHD/50V			
15	1	C51	C-SMD,15PCH			
16	1	C76	C-SMD,180PCH			
17	1	C99	C-SMD,			
			180PCH(3216)			
18	1	C133	C-SMD,1uF			

19	1	C132	C-SMD,1uFB			
20	1	C39	C-SMD,220PCH			
21	1	C43	C-SMD,270PCH			
22	3	C27	C-SMD,			
		C94-95	270PCH(3216)			
23	2	C11 C17	C-SMD,27PCH			
24	1	C98	C-SMD,			
			27PCH(3216)			
25	2	C10 C79	C-SMD,330PCH			
26	1	C88	C-SMD,			
			330PCH(2012)			
27	3	C9 C40	C-SMD,33PCH			
		C42				
28	1	C26	C-SMD,			
			390PCH(3216)			
29	1	C135	C-SMD,3PCH			
30	3	C116 C131	C-SMD,			
		C134	4.7uF(2012)			
31	1	C89	C-SMD,			
			470PCH(3216)			
32	2	C48-49	C-SMD,47PCH			
33	1	C100	C-SMD,			
			47PCH(2012)			
34	2	C18 C45	C-SMD,5PCH			

35	3	C6-7 C67	C-SMD,680PCH			
36	1	C87	C-SMD,68PCH			
37	2	C91 C115	C-SMD,			
			68PCH(2012)			
38	1	C15	C-SMD,7PCH			
39	1	C82	C-SMD,8PCH			
40	1	C12	C-SMD,C820PCH			
41	1	CF3	CF-A,455HT			
42	2	CF1-2	CF-A,CF10.7MS3			
43	1	CN2	CON-2,13.8V			
44	1	CN4	CON-10,			
			CONNECTOR			
45	1	CN1	CON-2B,IN-SP			
46	1	CN5	CON4-S			
47	1	CN3	CON6-S,			
			CONNECTOR			
48	1	CT1	CV-SMD,20P			
49	2	D20 D24	D-A,1N4002			
50	1	D11	D-A,KDR357			
51	3	D9 D13	D-A,S160			
		D15				
52	2	D2 D6	D-SOT23,S226			

53	2	D1 D5	D-USM,S181			
54	2	D4 D12	D-USM,S184			
55	2	D8 D14	D-V,SVC251			
56	1	D21	DZ-A,3.0VB			
57	1	D22	DZ-A,5.6VB			
58	1	D7	DZ-A,9.1VB			
59	1	TE8	E-A,1/16			
60	2	TE6 TE14	E-A,10/16			
61	2	CE8 CE14	E-A,100/16			
62	1	CE9	E-A,1000/16			
63	2	CE10 CE16	E-A,22/16			

64	1	TE4	E-A,3.3/16			
65	6	CE1-2 CE4	E-A,33/16			
		CE6 CE20				
		CE22				
66	1	CE15	E-A,330/16			
67	1	CE21	E-A,47/16			
68	1	EL17	E-A,470/16			
69	1	IC2	IC3,5V REG			
70	2	IC51-52	IC5,4558(1/2)			
71	1	IC5	IC5,TDA2003			
72	1	IC3	IC24-MFP24S,			
			LC7152M			
73	1	IC1	ICP16,MC3361		PLL-16PIN (DIP) PCB DECAL	
74	1	T3	IFT,047			
75	1	T6	IFT,81450A			
76	1	T7	IFT,81460N			
77	1	T4	IFT,LB335			
78	1	T1	IFT6,81410A			
79	1	T2	IFT6,81420			
80	2	T9-10	IFT6,81480			
81	1	T11	IFT6,LX18			
82	1	T5	IFT-5,036			
83	1	J1	J-SP,EXT SP			
84	1	J3	JUMPER		JUMPER BLOCK, 2 PINS 0.1"	
					SPACING	
85	1	L4	L-D			
86	1	L11	L-D,			
			220nH(2012)			
87	1	L3	L-D,			
			6.8uH(2012)			
88	1	L1	L-D,6T			
89	1	L9	L-D,7-1/2T			
90	5	L5-8 L10	L-D,8-1/2T			
91	1	R58	R-SMD,1.5K			
92	1	R12	R-SMD,1.5M			
93	5	R19 R84	R-SMD,100			

		R100-101			
		R133			
94	5	R13 R15	R-SMD,100K		
		R49			
		R114-115			
95	10	R25 R51	R-SMD,10K		
		R60 R67			
		R77-79			
		R95 R98			
		R113			
96	1	R107	R-SMD,		
			120(1/2W)		
97	1	R6	R-SMD,120K		
98	1	R70	R-SMD,15(2012)		
99	1	R117	R-SMD,150/1W		
100	1	R42	R-SMD,150K		
101	5	R5 R14	R-SMD,15K		
		R50 R66			
		R94			
102	1	R85	R-SMD,180K		
103	5	R18 R30	R-SMD,1K		
		R54 R93			
		R140			
104	1	R52	R-SMD,10K		
105	1	R64	R-SMD,2.2		
106	9	R3 R16	R-SMD,2.2K		
		R36 R46			
		R62 R65			
		R71 R91			
		R137			
107	4	R1 R20-21	R-SMD,2.7K		
		R76			
108	2	R22 R33	R-SMD,220		
109	3	R53 R57	R-SMD,220K		
		R99			



110	4	R31 R68	R-SMD,22K			
		R74-75				
111	2	R2 R89	R-SMD,27K			
112	2	R82-83	R-SMD,3.3K			
113	1	R96	R-SMD,3.9K			
114	4	R32 R97	R-SMD,330			
		R116 R119				
115	1	R88	R-SMD,330K			
116	5	R7 R37	R-SMD,33K			
		R41 R73				
		R90				

117	1	R118	R-SMD,390			
118	1	R69	R-SMD,4.7/2W			
119	2	R102-103	R-SMD,4.7K			
120	1	R144	R-SMD,			
			4.7K(2012)			
121	3	R35	R-SMD,47			
		R105-106				
122	1	R8	R-SMD,47(2012)			
123	1	R11	R-SMD,470			
124	6	R38-39	R-SMD,47K			
		R43 R55				
		R80-81				
125	2	R87 R104	R-SMD,5.6K			
126	1	R56	R-SMD,56			
127	2	R24 R34	R-SMD,56K			
128	1	R61	R-SMD,6.8K			
129	1	R108	R-SMD,68			
130	1	R109	R-SMD,68(2012)			
131	1	R122	R-SMD,680			
132	1	R40	R-SMD,68K			
133	1	R4	R-SMD,8.2K			
134	1	R112	R-SMD,820			

135	1	R17	R-SMD,82K			
136	1	Q21	T-220AB,A101S			
137	1	Q35	T-220AB,A1241Y			
138	1	Q29	T-220AB,A1504Y			
139	1	Q34	T-220AB,B988Y			
140	6	Q5 Q13-14	T-220AB,C102S			
		Q22 Q24				
		Q27				
141	1	Q25	T-220AB,C104S			
142	1	Q33	T-220AB,C2078E			
143	1	Q32	T-220AB,C2314F			
144	1	Q31	T-220AB,			
			C3199GR			
145	8	Q1 Q10-11	T-220AB,C3875Y			
		Q15 Q20				
		Q23 Q28				
		Q36				
146	6	Q2 Q8-9	T-220AB,C3880Y			
		Q16-17				
		Q30				
147	1	VM8	TP1,+			
148	1	OPT1	TRANS,24MM			
149	1	CH1	TRANS2,19MM			
150	1	VR4	VR-5H3P,1KB			

151	1	VR6	VR-5H3P,470B			
152	1	VR3	VR-6H3P,5KB			
153	1	X1	XTL-11X4.5,			
			10.245MHZ			

-----|

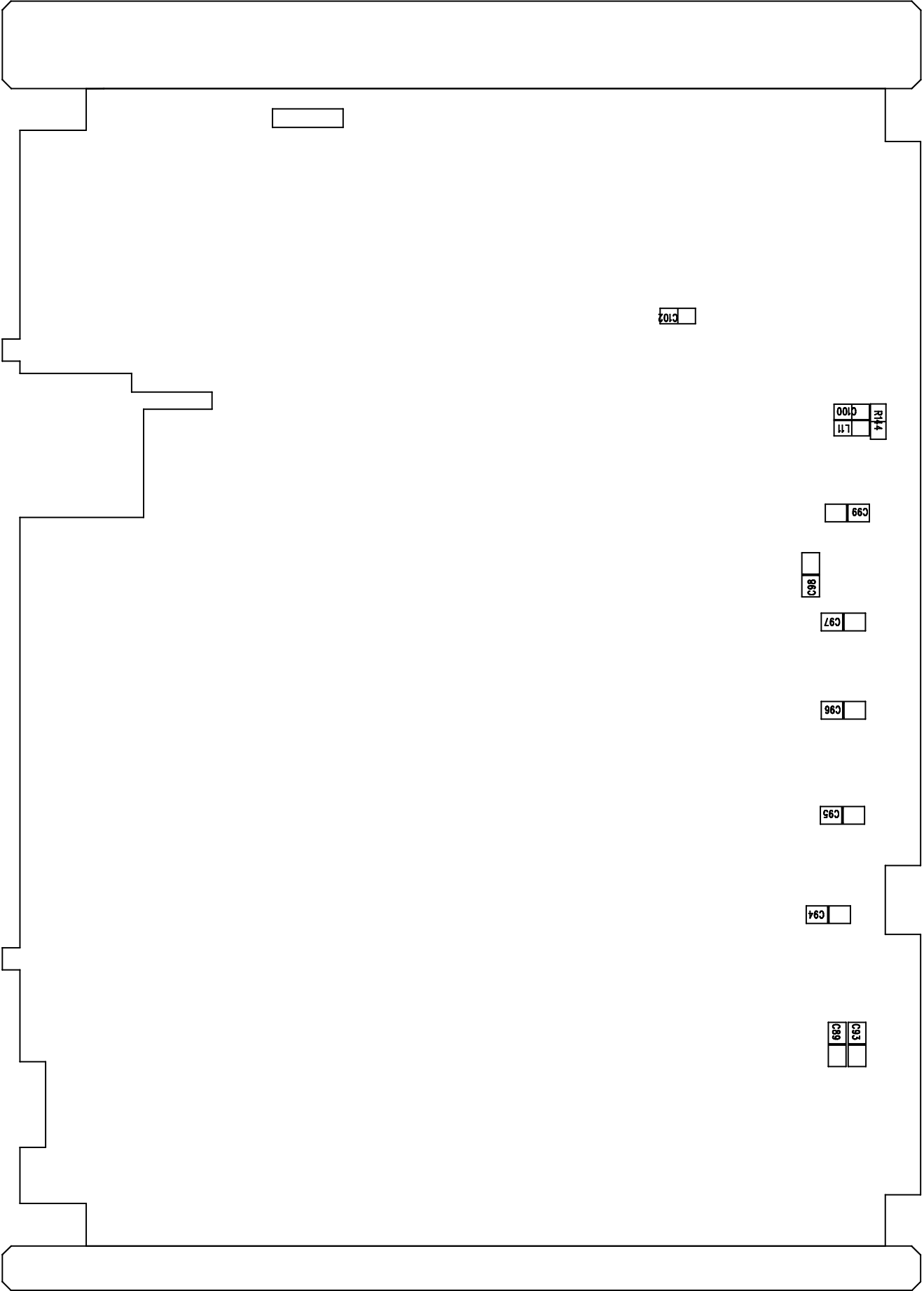

102

R14	
L11	
Q100	

C99

C98

C97

C96

C95

C94

C93	
C98	

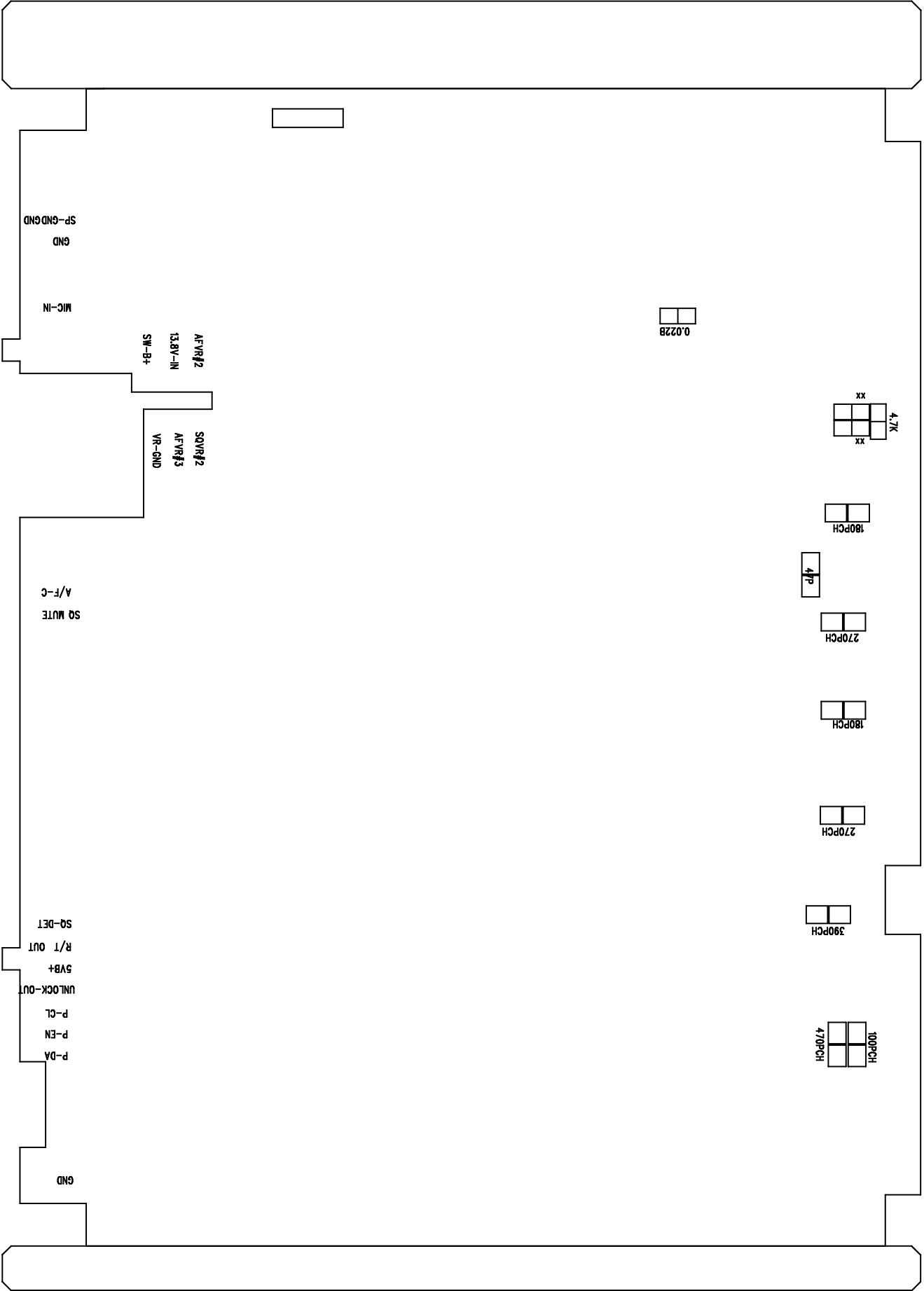





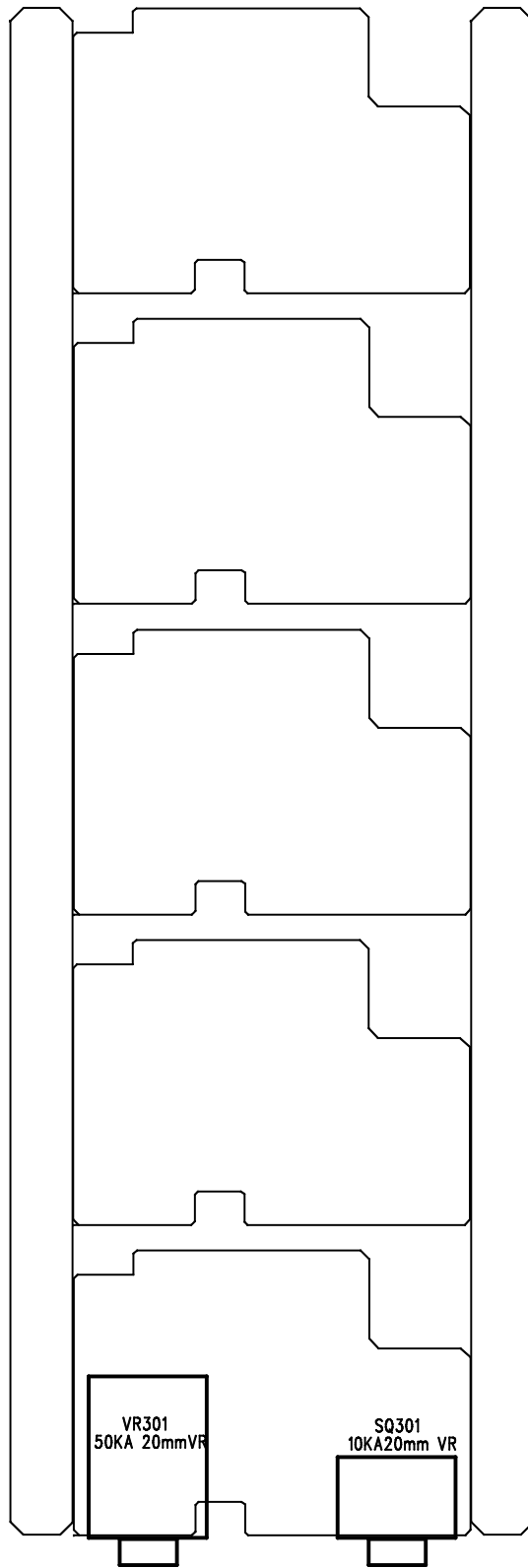

# MJ-300 BLOCK DIAGRAM

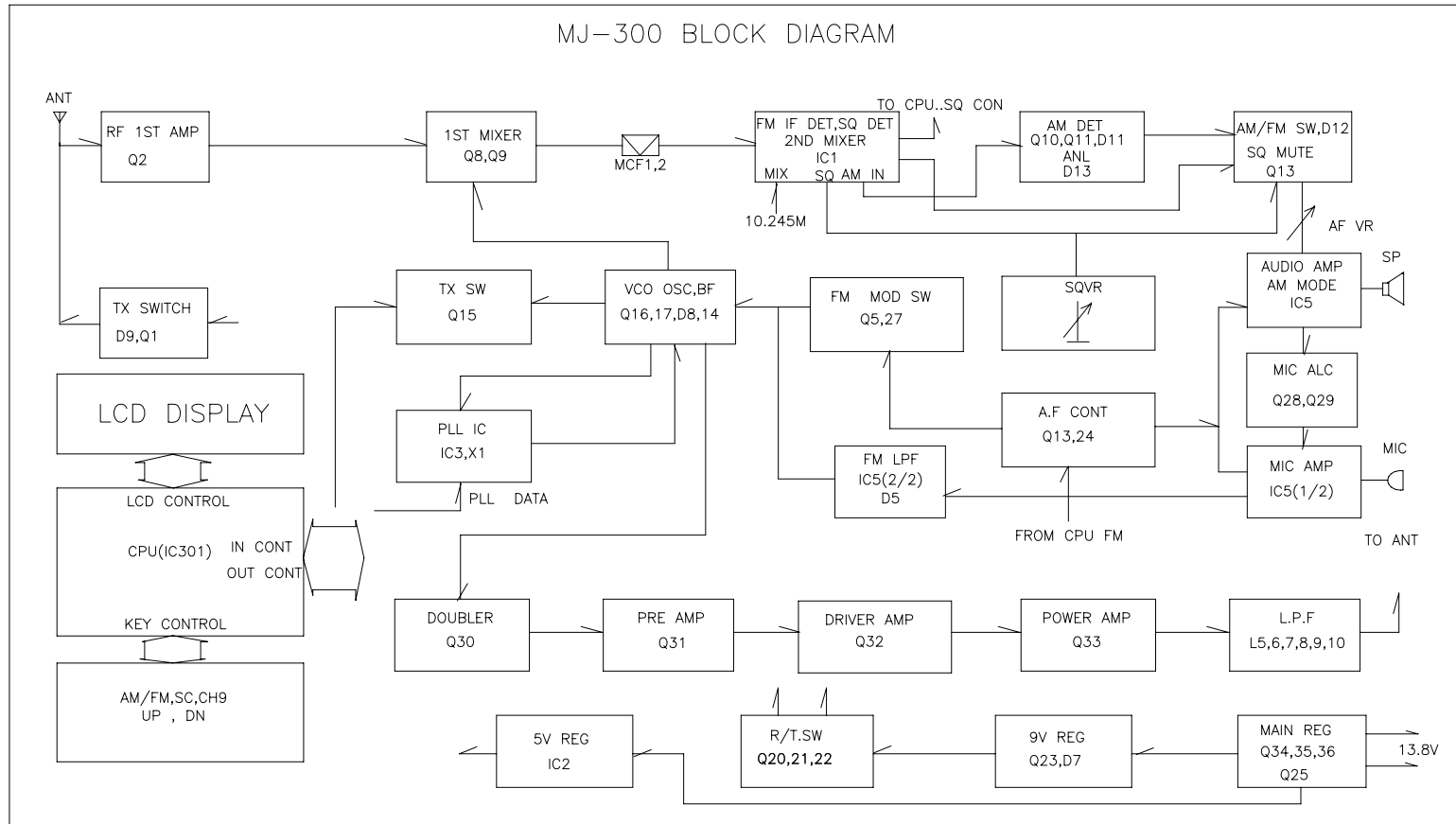



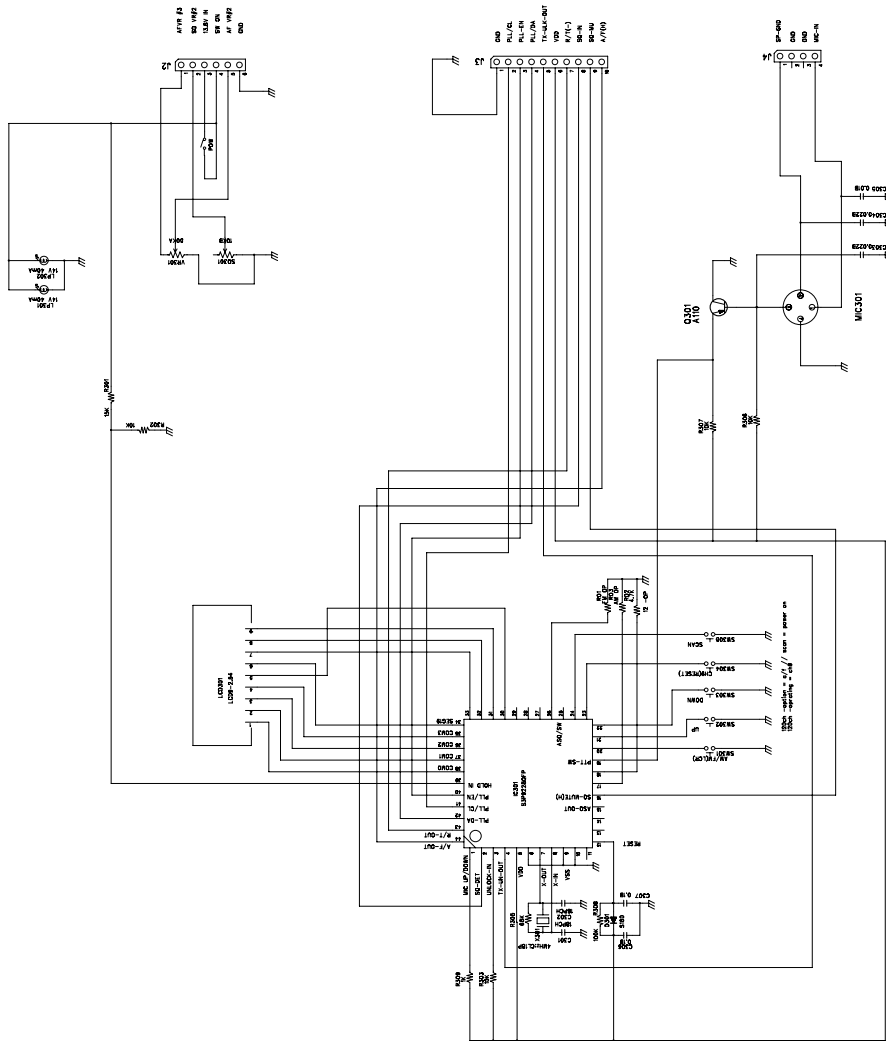

BUYER MODEL	MJ-300FEU
BASIC MODEL	MJ300FRONT-EU
REV:	06/05/25