

# PRESIDENT™

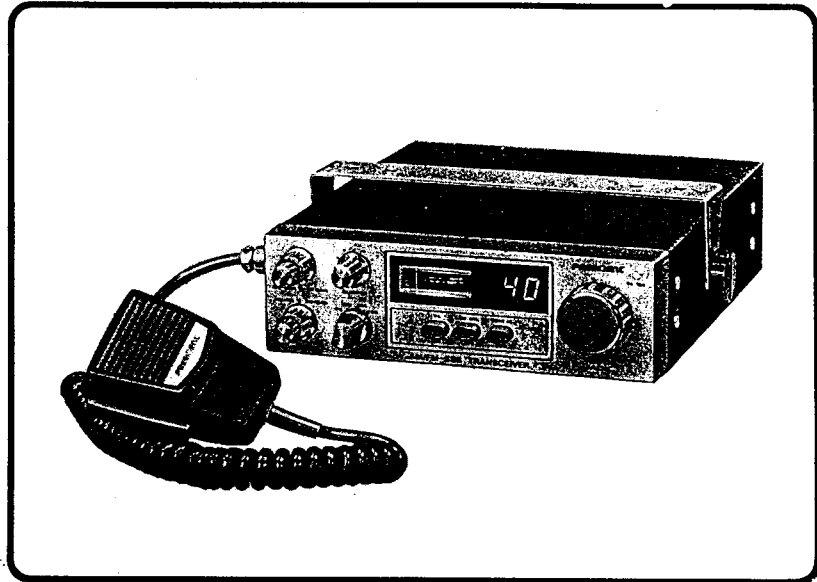

*www.cbradio.nl*  
thanks Homer  
*for sharing this file*

**JACK**

## SERVICE MANUAL

## ALIGNMENT OF PLL & CARRIER OSCILLATOR PORTION

### 1. Test Equipment Required

- a). RF VTVM
- b). DC Power Supply (13.8V)
- c). Frequency Counter (0 - 50MHz)
- d). 50 ohm Load.

### 2. Alignment Procedure

STEP	PRESET TO	ADJUSTMENT	REMARKS
1	Channel: 40 Mode: AM, RX. Clari: Center Tone: Low PA/CB: CB	L16	Connect RF VTVM to TP4 (lead of R112). Adjust L16 for the maximum indication on oscilloscope.
2	Same as above EXEPT	L17	Connect DC Voltmeter to TP2 (lead of R117). Adjust L17 to obtain 5.5V reading and confirm beyond 2V in Low Band, channel 1.
3	Same as Step 1	L18	Connect RF VTVM to TP3 (lead of R81). Adjust L18 for the maximum reading.
4	Same as Step 1	L20	Connect Frequency counter to TP3 (lead of R81). Adjust L20 to obtain 16.7100MHz reading.
5	Mode: USB, RX.	L21	Adjust L21 to obtain 16.7125MHz reading.
6	Mode: LSB, RX.	L22	Adjust L22 to obtain 16.7075MHz reading.
7	Mode: LSB, TX.	VR6	Adjust VR6 to obtain 16.7075MHz reading.
8	Mode: LSB, RX.	L25	Connect Frequency counter to TP5 (lead of R53). Adjust L25 to obtain 10.6975MHz reading.
9	Mode: USB, RX.	L24	Adjust L24 to obtain 10.6925MHz reading.
10	Mode: AM, TX.	L23	Connect Frequency counter to TP9(lead of R84). Adjust L23 to obtain 10.6950MHz reading.

### 3. Test Equipment Connection

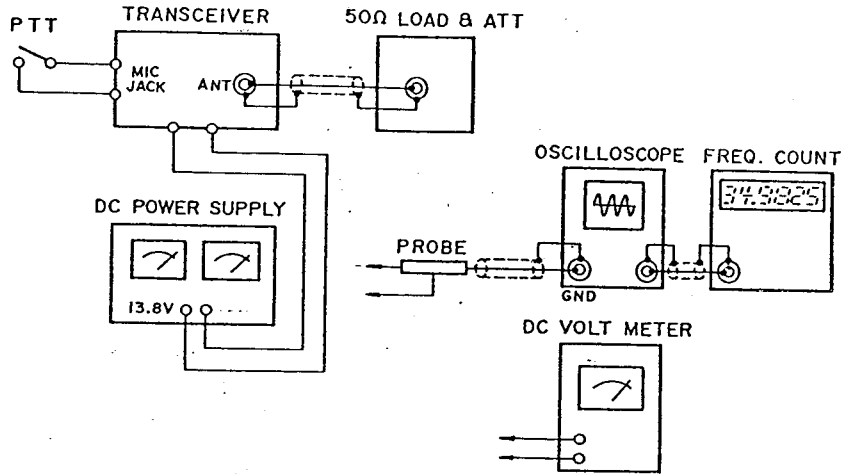

# Alignment Test Point

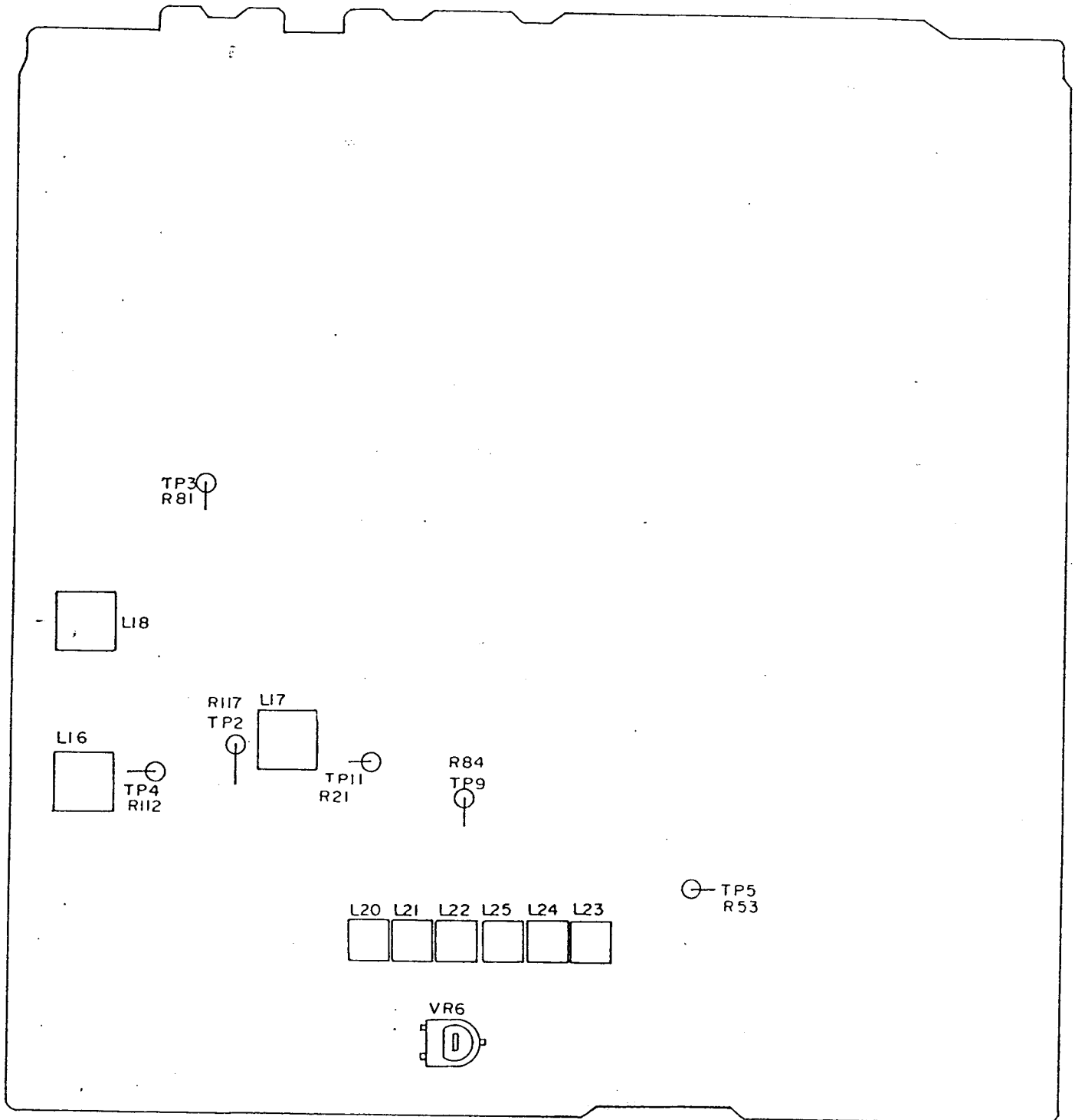

## ALIGNMENT OF TRANSMITTER PORTION

### 1. Test Equipment Required

- a). AF Signal Generator (1) for 500Hz and 1,000Hz
- b). AF Signal Generator (2) for 2,400Hz
- c). AF VTVM (150mV full scale)
- d). RF VTVM (50V full scale)
- e). RF Powermeter (10W Max. Thru-line type)
- f). 50 ohm Dummy Load
- g). Oscilloscope
- h). Harmonic Meter
- i). DC Voltmeter
- j). DC Ammeter (150mA full scale)

### 2. Alignment Procedure

STEP	PRESET TO	ADJUSTMENT	REMARKS
1	Channel: 19 Mode: USB, TX. No Modulation	VR10	Connect DC Ammeter to TP8(+), TP7(-). Disconnect the PC-834AA. Adjust VR10 to obtain the current approx. 8mA.
2	Same as Step 1	VR9	Connect DC Ammeter to TP8(+), TP6(-). Adjust VR9 to obtain the current approx. 100mA.
3	Channel: 19 Mode: USB, TX. AF SG: 30mV, Two Tone 500 and 2400Hz	L43 and L44	Disconnect the DC Ammeter. Connect PC-834. Connect Powermeter, RF VTVM & Oscilloscope. Set VR7 CW Max. Adjust the peak indication of coils to 19CH.
4	Same as above except Channel: 19	L42	Turn the core of L41 to be flat with upper side of the coil's cover. Adjust L42 for the maximum indication.
5	Same as above except Channel: 19	L41	Adjust L41 for the maximum indication. While then, keep output voltage under 20V by adjusting SG.
6	Same as above Channel: 1 40	L41	Adjust L41 to obtain the minimum difference on the RF power meter between Channel 40 and Channel 1.
7	Channel: 19 Mode: AM, TX. 90% modulation	L30	Adjust L30 to obtain the maximum indication on the RF VTVM.
8	same as step 3	VR7	Adjust VR7 to obtain RF output of 24.5V on the RF VTVM.
9	Same as Step 1	VR4	Adjust VR4 to obtain the minimum carrier leakage.

STEP	PRESET TO	ADJUSTMENT	REMARKS
10	Same as Step 1 except LSB	VR4	Same as above
11	Repeat Steps 9 and 10 to obtain approximately the same amount of minimum carrier leakage on USB and LSB modes.		
12	Channel: 19 Mode: AM, TX. No Modulation	VR11	Adjust VR11 to obtain RF carrier power of 5.0W on RF Power meter.
13	Same as above	VR8	Adjust VR8 to obtain an indication of marked position on built-in meter.
14	Same as above except AF SG: 30mV 1KHz Mod.	VR5	Adjust VR5 to obtain 90% (negative) modulation.
15	Same as above except Mode: FM	VR3	Connect Deviation meter. AF SSG supplies 1KHz, 30mV. Adjust VR3 to obtain 4.5KHz Deviation on Deviation meter.

### 3. Test Equipment Connection

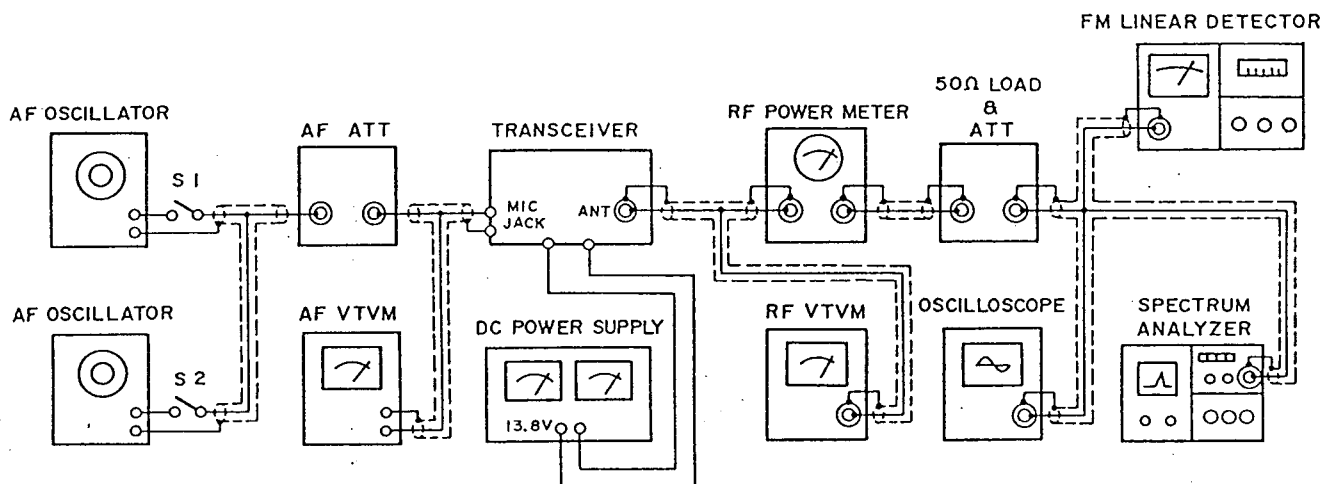

Alignment Test Point



VR10



VR9



L30



TP7



TP6



TP8

VR8



VR7



VR5



VR11



L42



L41



L43



L44



VR3



VR4

## ALIGNMENT OF RECEIVER PORTION

### 1. Test Equipment Required

- a). RF SSG
- b). DC Voltmeter
- c). AF VTVM
- d). Oscilloscope

### 2. Alignment Procedure

Connect the AF VTVM and 8 ohm dummy load to EXT SP Jack during the alignment of receiver portion.

STEP	PRESET TO	ADJUSTMENT	REMARKS
1	Channel: 19 NB/ANL: OFF SQL: OFF RF GAIN: Max AF VOL: Max MODE: AM CB/PA: CB		Set RF SG to 27.185MHz with 30%, 1kHz modulation.
2	Same as above	L7	Turn the core of L7 to CW. maximum at the bottom.
3	Same as above	L6, 8, 10, 11 12, 13, 14.	Adjust coils to obtain the maximum AF output power. While then, keep output under 500mW by adjusting RF SG.
4	Same as above	L7	Adjust L7 to obtain the maximum AF output power.
5	Channel: 18 Mode: AM AB/ANL: ON Band: mid.	L1 and L2	Connect oscilloscope to TP1. Set RF SSG to 18ch with no modulation. (SG ATT.:20dB) Adjust L1 and L2 to obtain the maximum DC voltage.
6	Channel: 19 Mode: AM SQL: MAX	VR2	Set SSG 19ch, 1KHz, 30% Mod. Adjust VR2 to turn off the squelch circuit when SSG output comes up to 1000uV.
7	Same as above	VR1	Set the SSG to 100uV output with no-modulation. Adjust VR1 to obtain "S-9" on transceiver's meter.



STEP	PRESET TO	ADJUSTMENT	REMARKS
8	CH: 19 Mode: FM	L3 and L4	Set the SSG to 5uV, NO Modulation. Connect Oscilloscope to TP10(lead of R279). Adjust Coils to obtain the maximum indication on Oscilloscope.
9	Same as above	L5	Set the SSG to FM 1KHz, 1.5KHz Deviation 1mV. Adjust L5 to obtain the maximum indication on Oscilloscope.

### 3. Test Equipment Connection

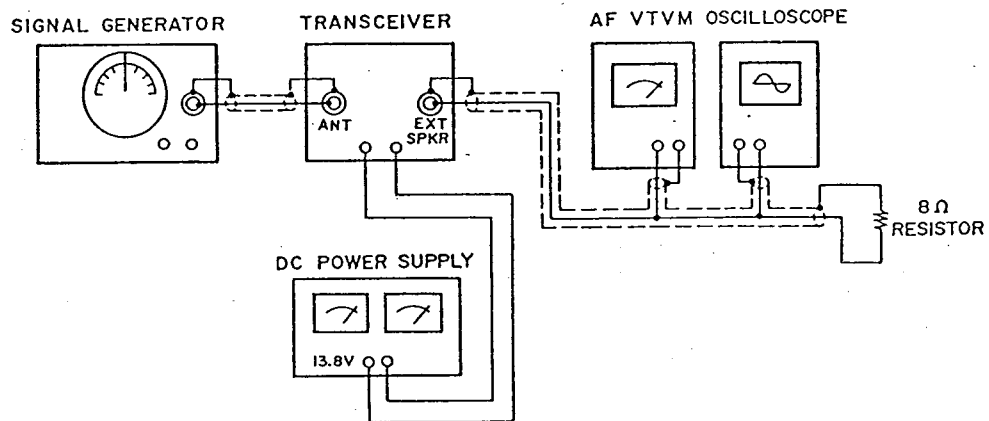

Alignment Test Point

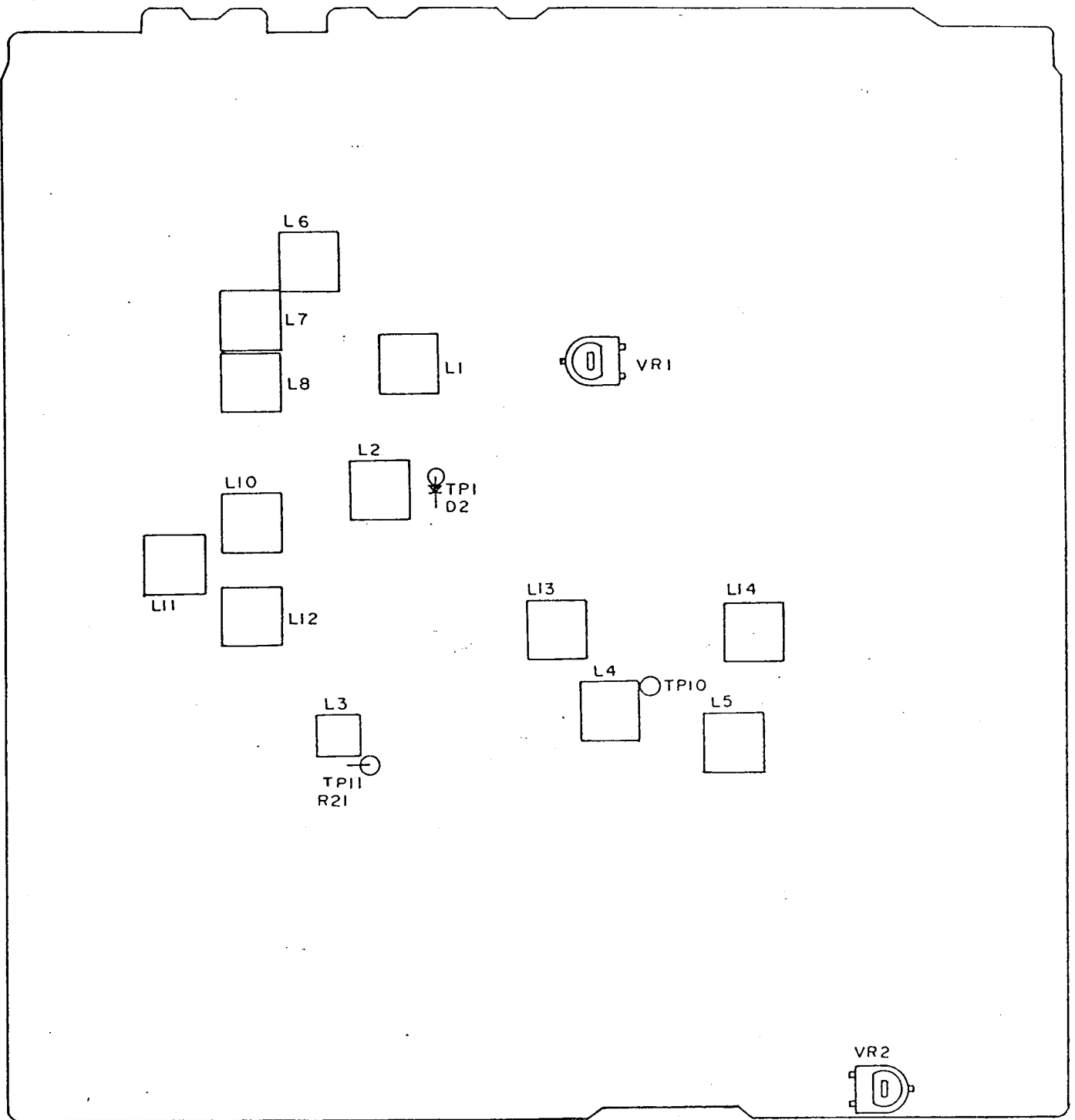

FREQUENCIES OF LOCAL OSCILLATORS AND IF STAGE IN RECEIVING STATE

Channel No.	Reception Frequencies (MHz)	Divide Ratio (N)	Local Oscillator Frequencies (MHz)		
			AM/FM mode	USB mode	LSB mode
1	26.965	79	16.270	16.2725	16.2675
2	.975	80	16.280	16.2825	16.2775
3	.985	81	16.290	16.2925	16.2875
4	27.005	83	16.310	16.3125	16.3075
5	.015	84	16.320	16.3225	16.3175
6	.025	85	16.330	16.3325	16.3275
7	.035	86	16.340	16.3425	16.3375
8	.055	88	16.360	16.3625	16.3575
9	.065	89	16.370	16.3725	16.3675
10	.075	90	16.380	16.3825	16.3775
11	.085	91	16.390	16.3925	16.3875
12	.105	93	16.410	16.4125	16.4075
13	.115	94	16.420	16.4225	16.4175
14	.125	95	16.430	16.4325	16.4275
15	.135	96	16.440	16.4425	16.4375
16	.155	98	16.460	16.4625	16.4575
17	.165	99	16.470	16.4725	16.4675
18	.175	100	16.480	16.4825	16.4775
19	.185	101	16.490	16.4925	16.4875
20	.205	103	16.510	16.5125	16.5075
21	.215	104	16.520	16.5225	16.5175
22	.225	105	16.530	16.5325	16.5275
23	.255	108	16.560	16.5625	16.5575
24	.235	106	16.540	16.5425	16.5375
25	.245	107	16.550	16.5525	16.5475
26	.265	109	16.570	16.5725	16.5675
27	.275	110	16.580	16.5825	16.5775
28	.285	111	16.590	16.5925	16.5875
29	.295	112	16.600	16.6025	16.5975
30	.305	113	16.610	16.6125	16.6075
31	.315	114	16.620	16.6225	16.6175
32	.325	115	16.630	16.6325	16.6275
33	.335	116	16.640	16.6425	16.6375
34	.345	117	16.650	16.6525	16.6475
35	.355	118	16.660	16.6625	16.6575
36	.365	119	16.670	16.6725	16.6675
37	.375	120	16.680	16.6825	16.6775
38	.385	121	16.690	16.6925	16.6875
39	.395	122	16.700	16.7025	16.6975
40	.405	123	16.710	16.7125	16.7075

---

1st IF Frequency is 10.695 MHz on all of 40 channels.

1A

B/B

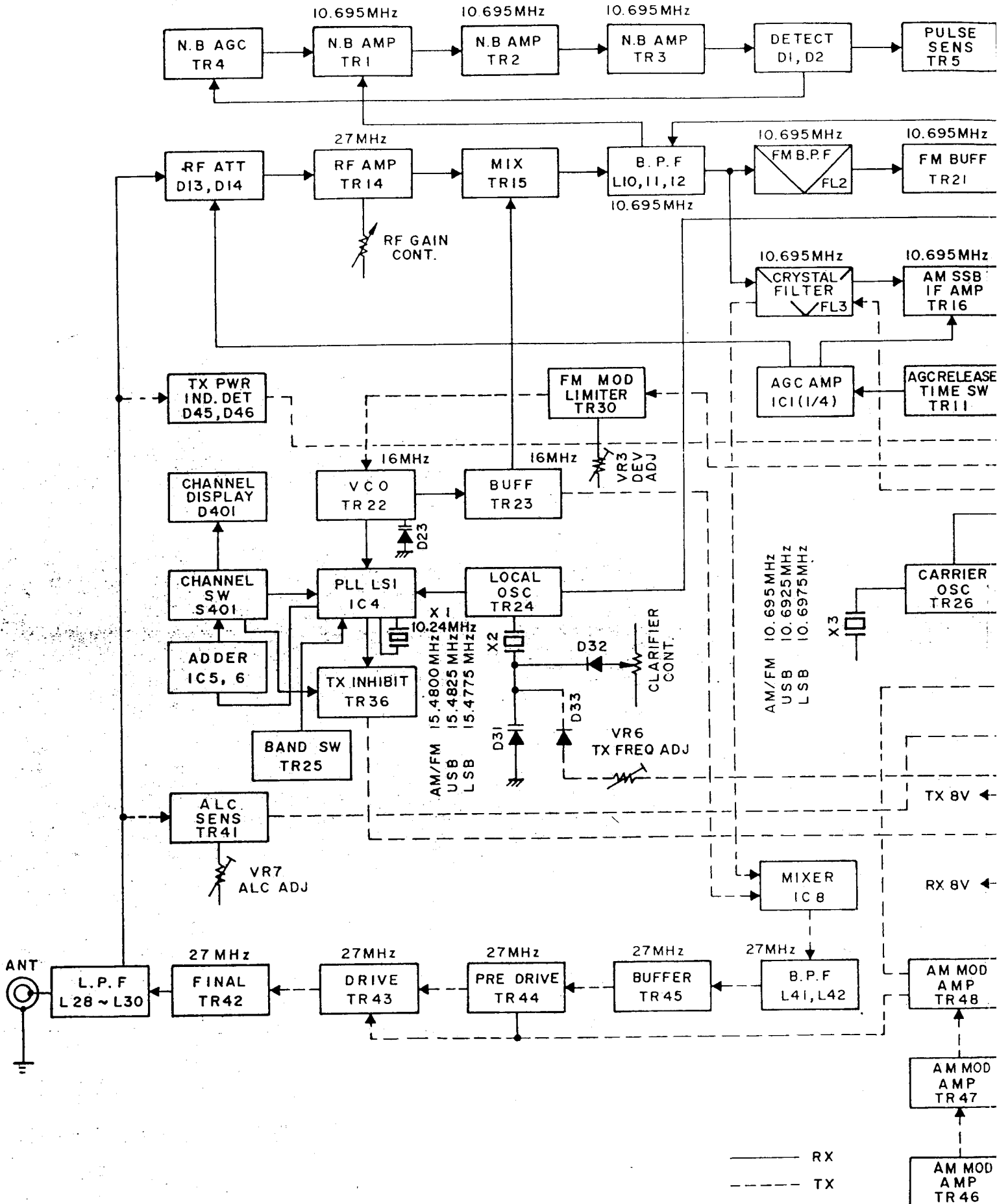

B/B

IC

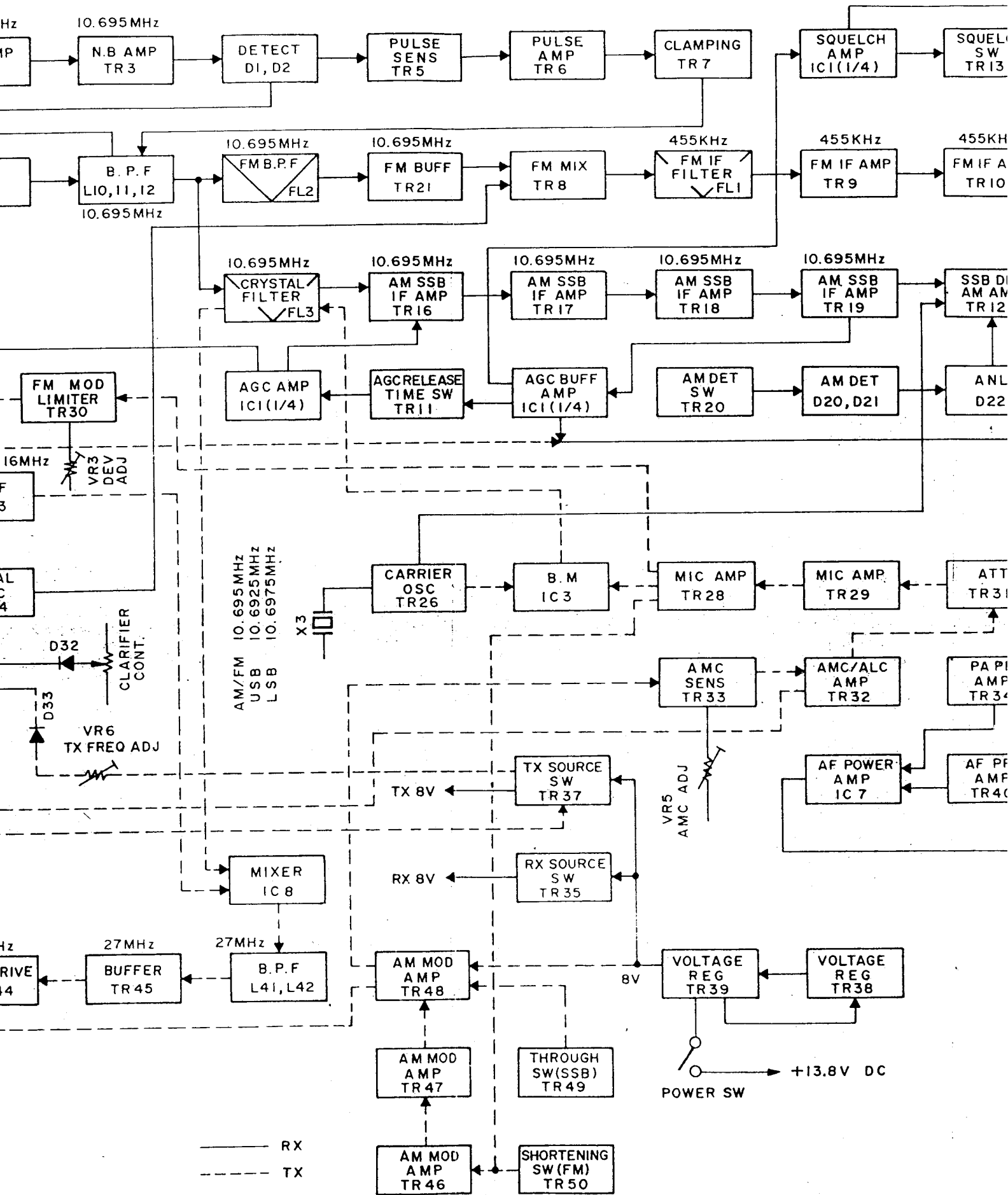

IC

10

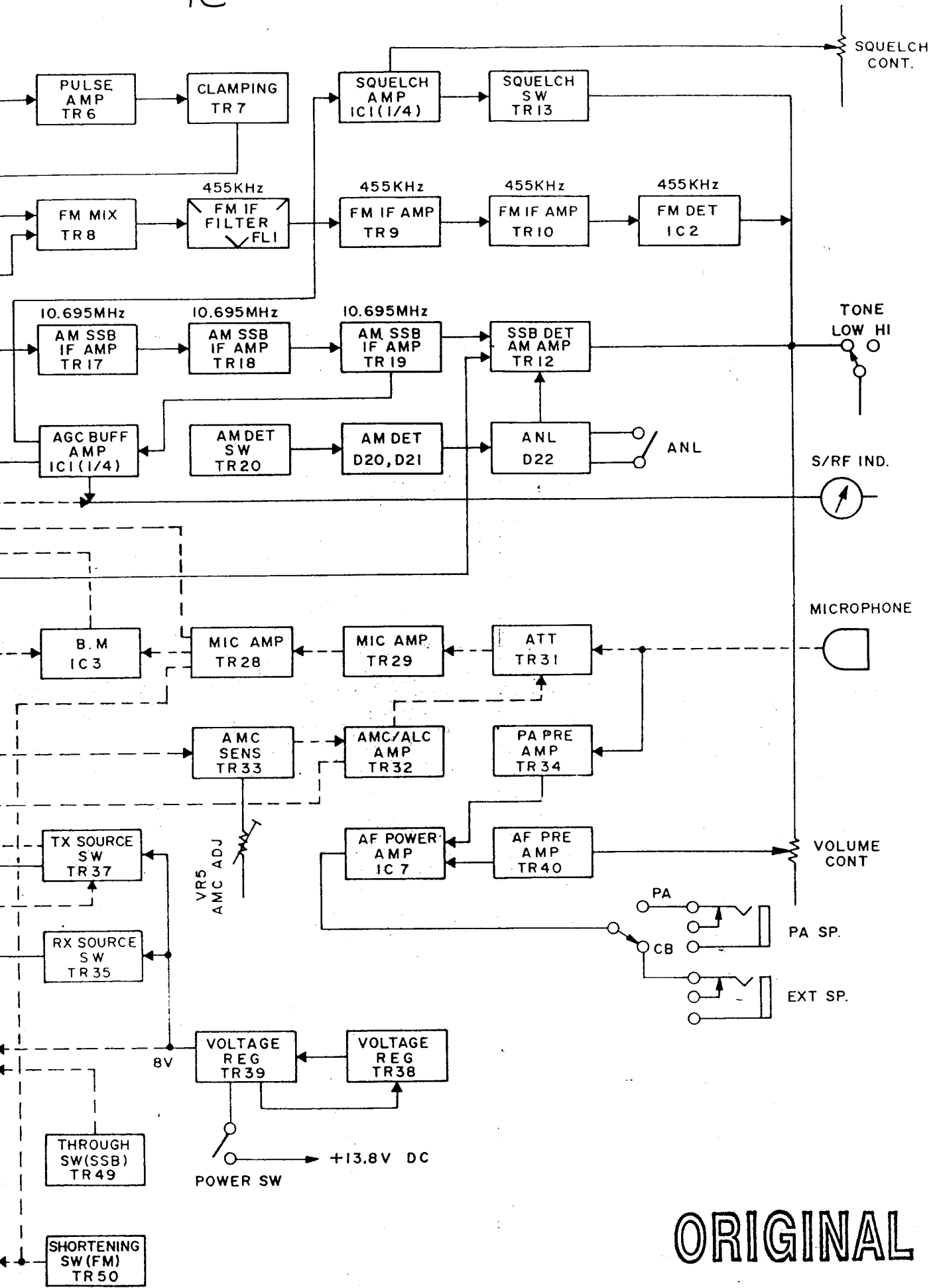

ORIGINAL

BLOCK DIAGRAM  
MODEL: JACK

UT-539D

2A

2B

# PRESIDENT

ORIGINAL

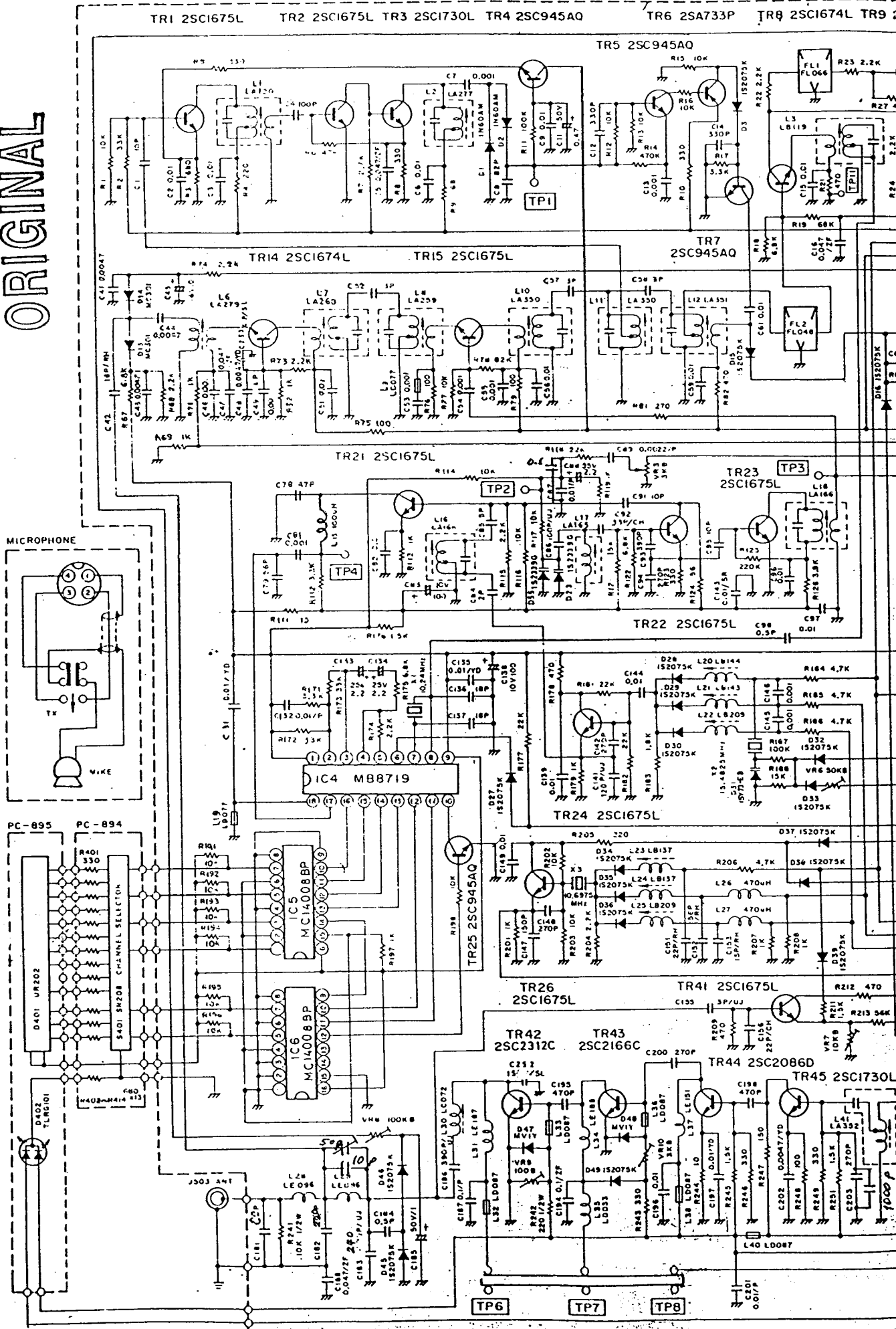

2B

2C

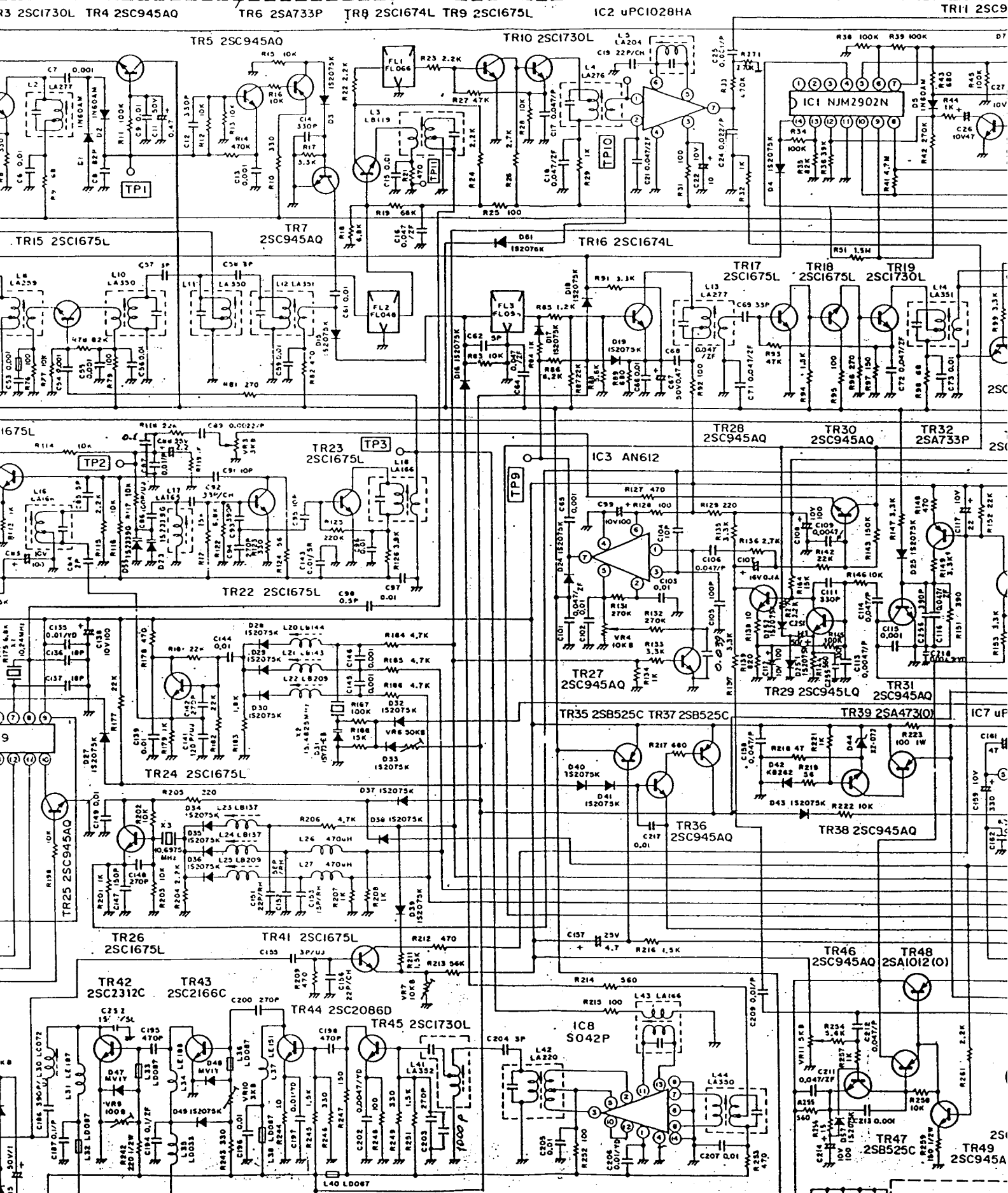

NOTES:  
 1. RESISTANCE VALUE OTHERWISE NOT NOTED.  
 2. RESISTOR WATTAGE NOTED.  
 3. CAPACITANCE VALUE UNLESS OTHERWISE NOTED.  
 4. ALL CAPACITORS ARE 50V UNLESS OTHERWISE NOTED.



20

20  
JACK

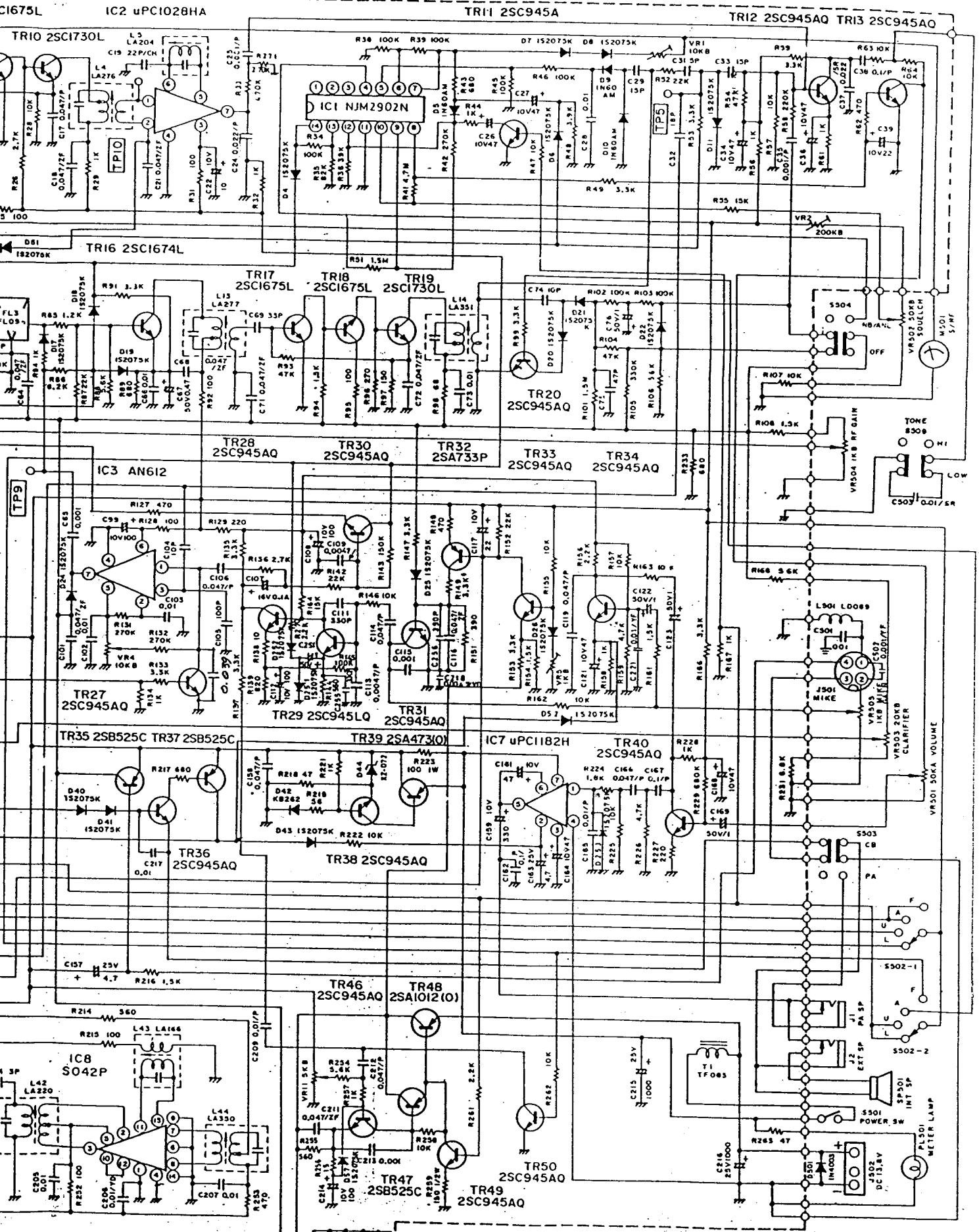

- NOTES:
1. RESISTANCE VALUES ARE SHOWN IN OHMS UNLESS OTHERWISE NOTED. (K=10<sup>3</sup> OHM, M=10<sup>6</sup> OHM)
  2. RESISTOR WATTAGES ARE 1/8W UNLESS OTHERWISE NOTED.
  3. CAPACITANCE VALUES ARE INDICATED IN MICROFARADS UNLESS OTHERWISE NOTED. (P=MICRO-MICROFARAD)
  4. ALL CAPACITORS TEMPERATURE CHARACTERISTICS ARE B1 (LESS THAN 100PPM) OR V1 (MORE THAN 100PPM) UNLESS OTHERWISE NOTED.

DESIGN BY	DRAWN BY	UNIDEN NO.	MODEL NO.
59.2.23		UT-539D	JACK
APPROV BY		E12-2248	

## BRANCHEMENT PRISE MICRO 6 BROCHES NC 518

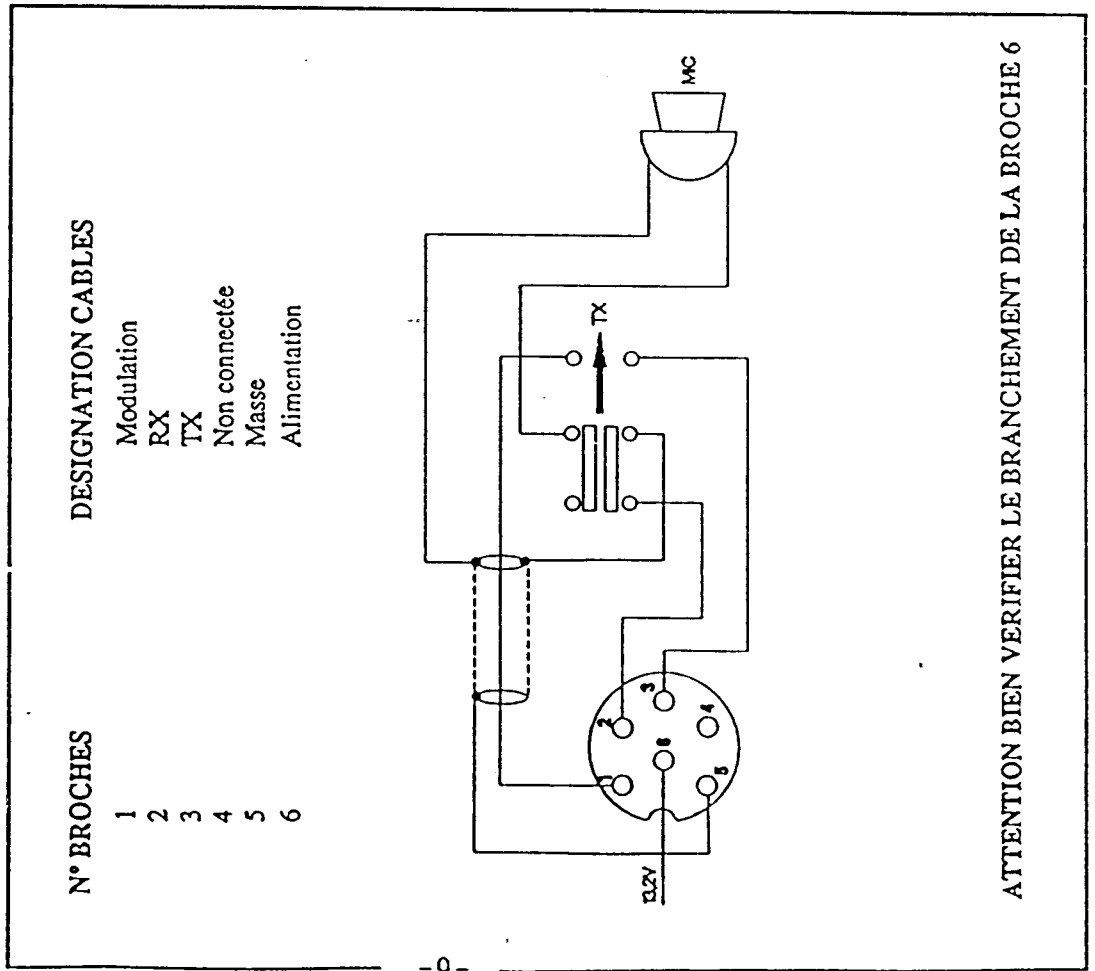

## BRANCHEMENT PRISE MICRO 4 BROCHES NC 514

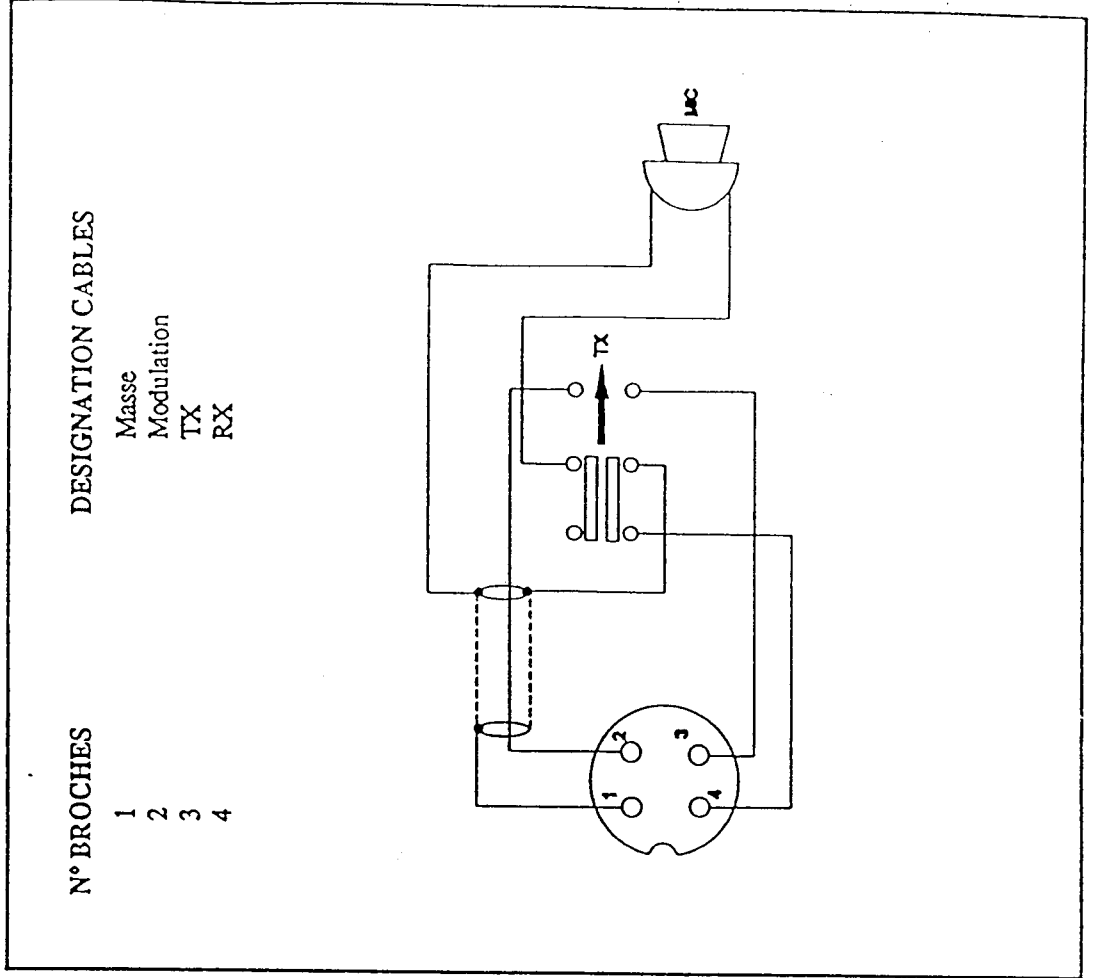

IC2 UPCI028HA

TR11 2SC945A

TR12 2SC945AQ TR13 2SC945AQ

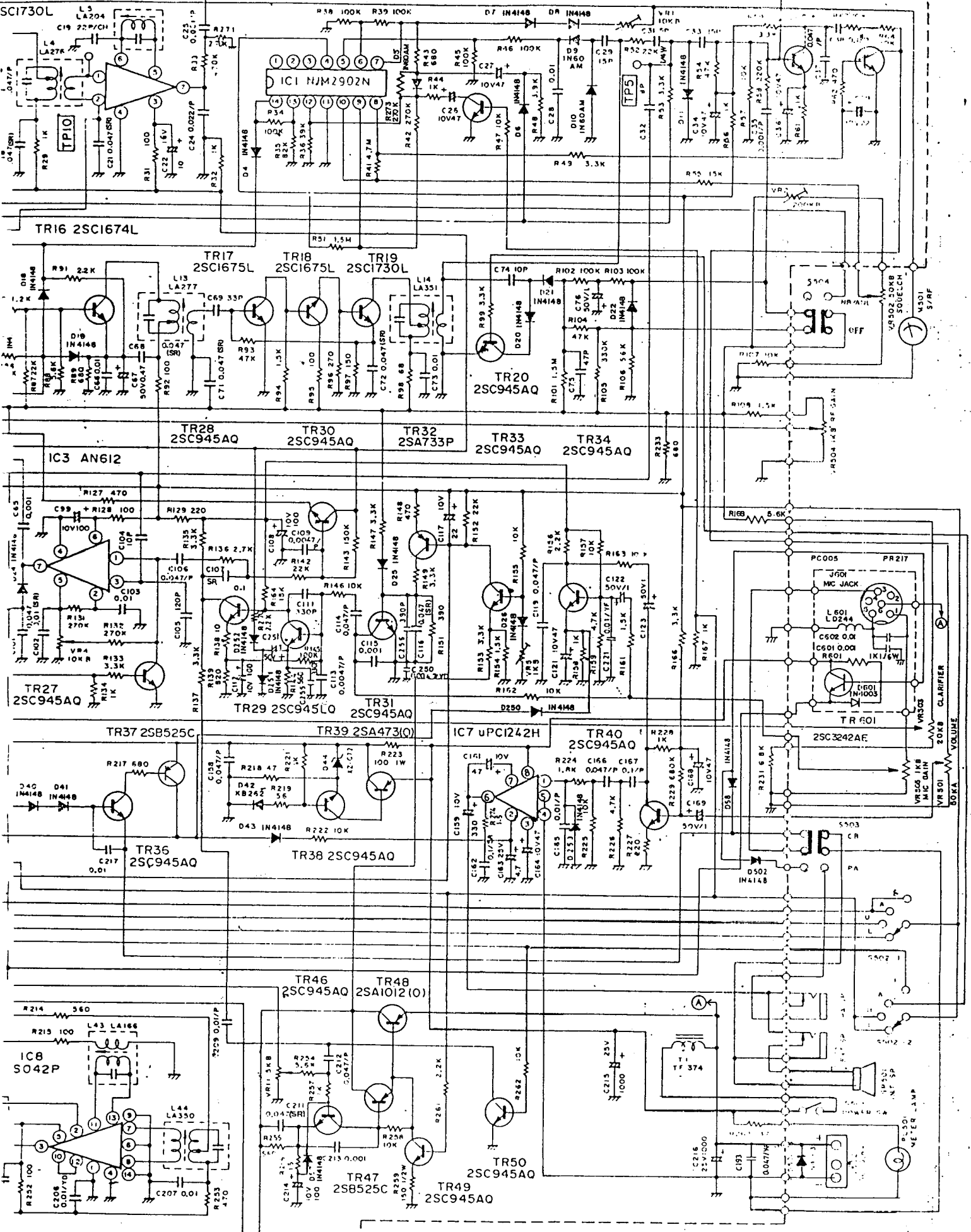

NOTES:

1. RESISTANCE VALUES ARE SHOWN IN OHMS UNLESS OTHERWISE NOTED. (K = 10<sup>3</sup> OHM M = 10<sup>6</sup> OHM)
2. RESISTOR WATTAGES ARE 1/6W UNLESS OTHERWISE NOTED.
3. CAPACITANCE VALUES ARE INDICATED IN MICROFARADS UNLESS OTHERWISE NOTED. (P = MICRO-MICROFARAD)
4. ALL CAPACITORS TEMPERATURE CHARACTERISTICS ARE SL (LESS THAN 1000PF) OR TF (MORE THAN 1000PF) UNLESS OTHERWISE NOTED.

DESIGN BY	IPAWN R1	NOUVEAU JACK	MODEL NO.
WRO C.	YINHO C.		
CHECK BY	WPTRO W1	SCHEMATIC DIAGRAM	

ES2-0150

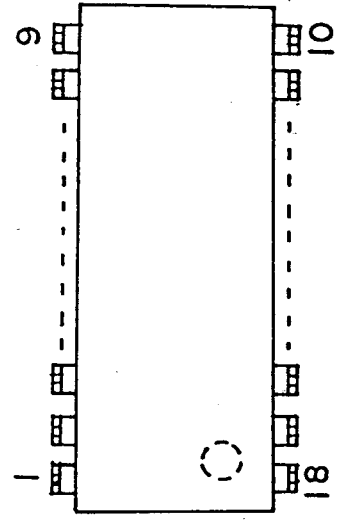
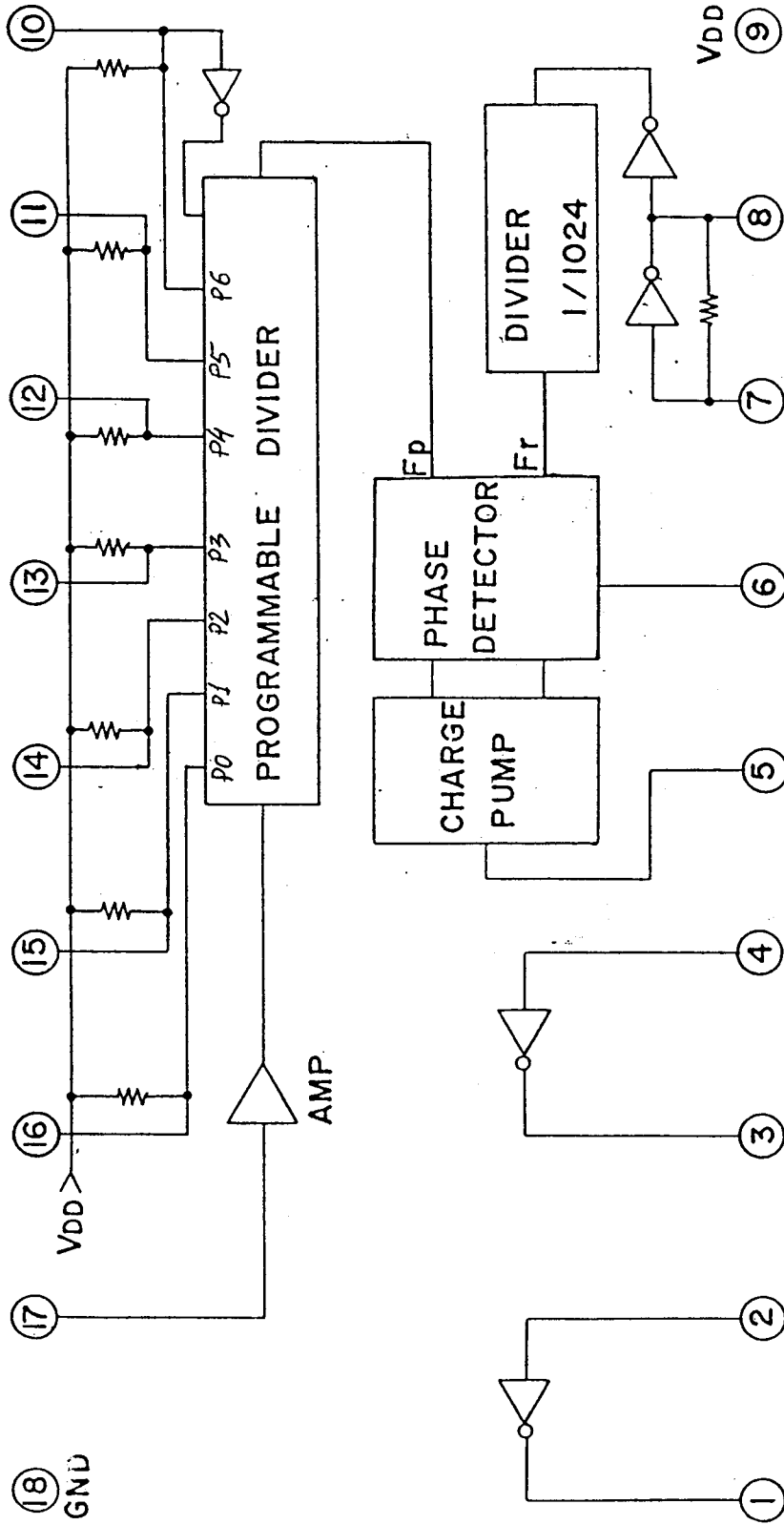

MC14008BCP

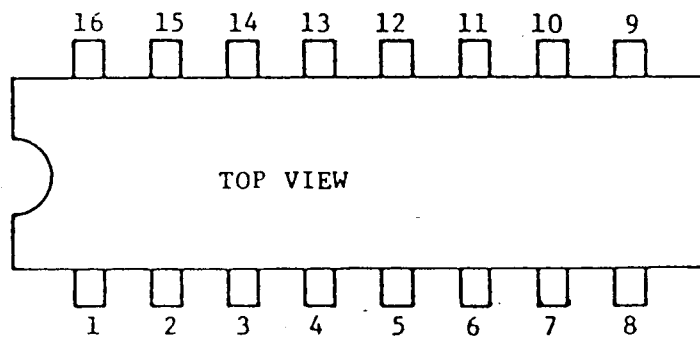
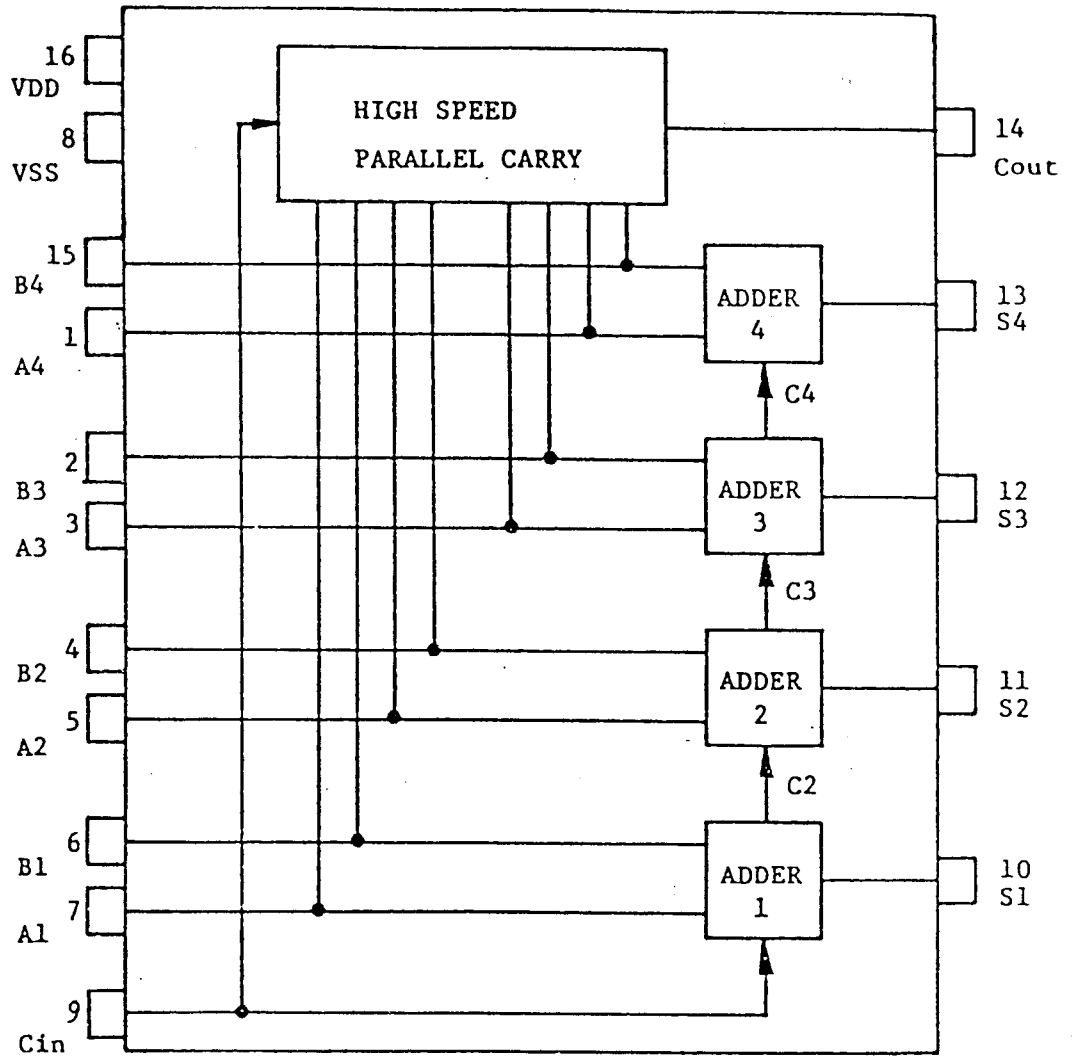

3A

3B

PC-893AC

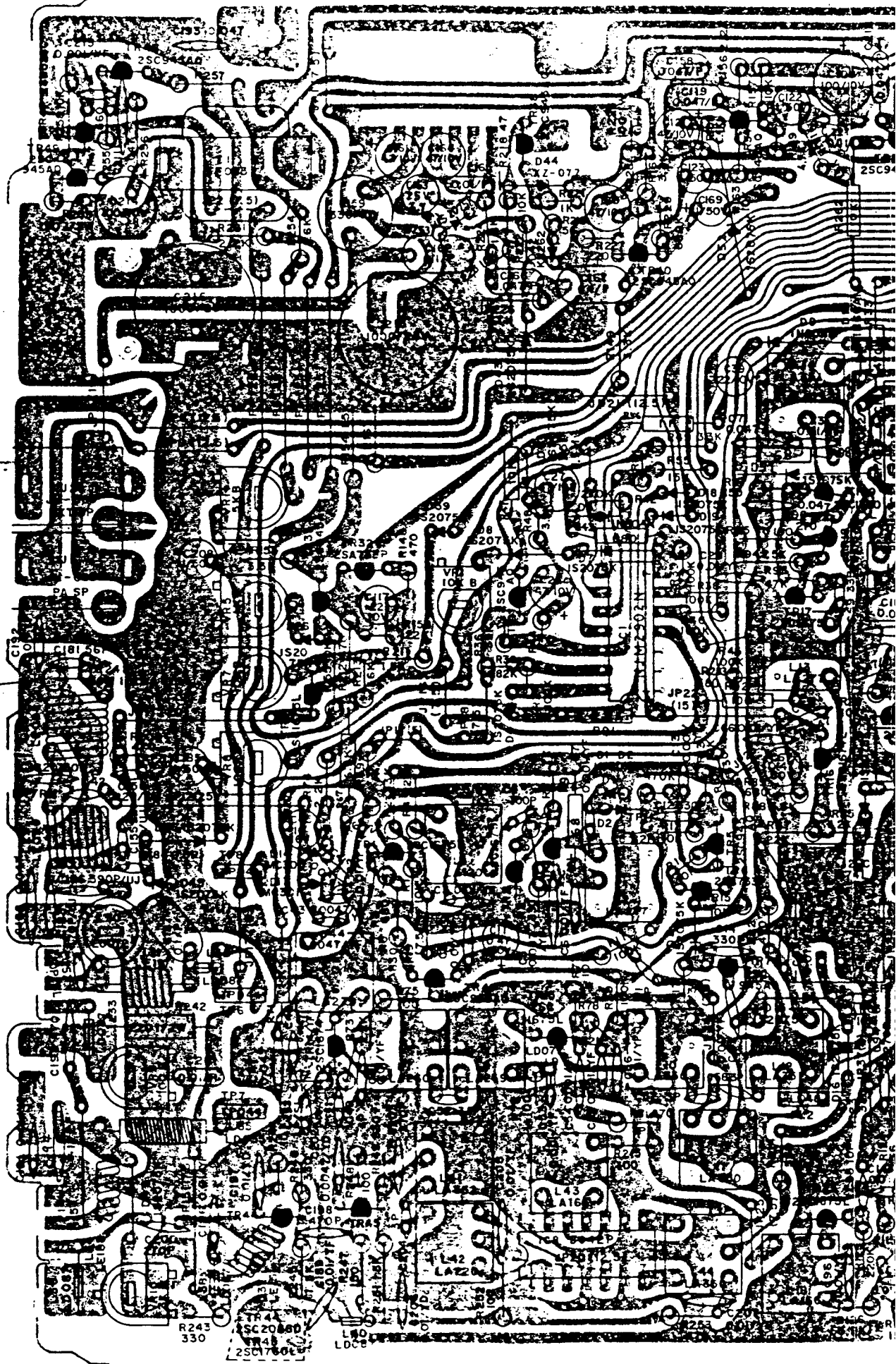
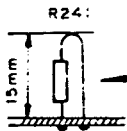

3B

3C

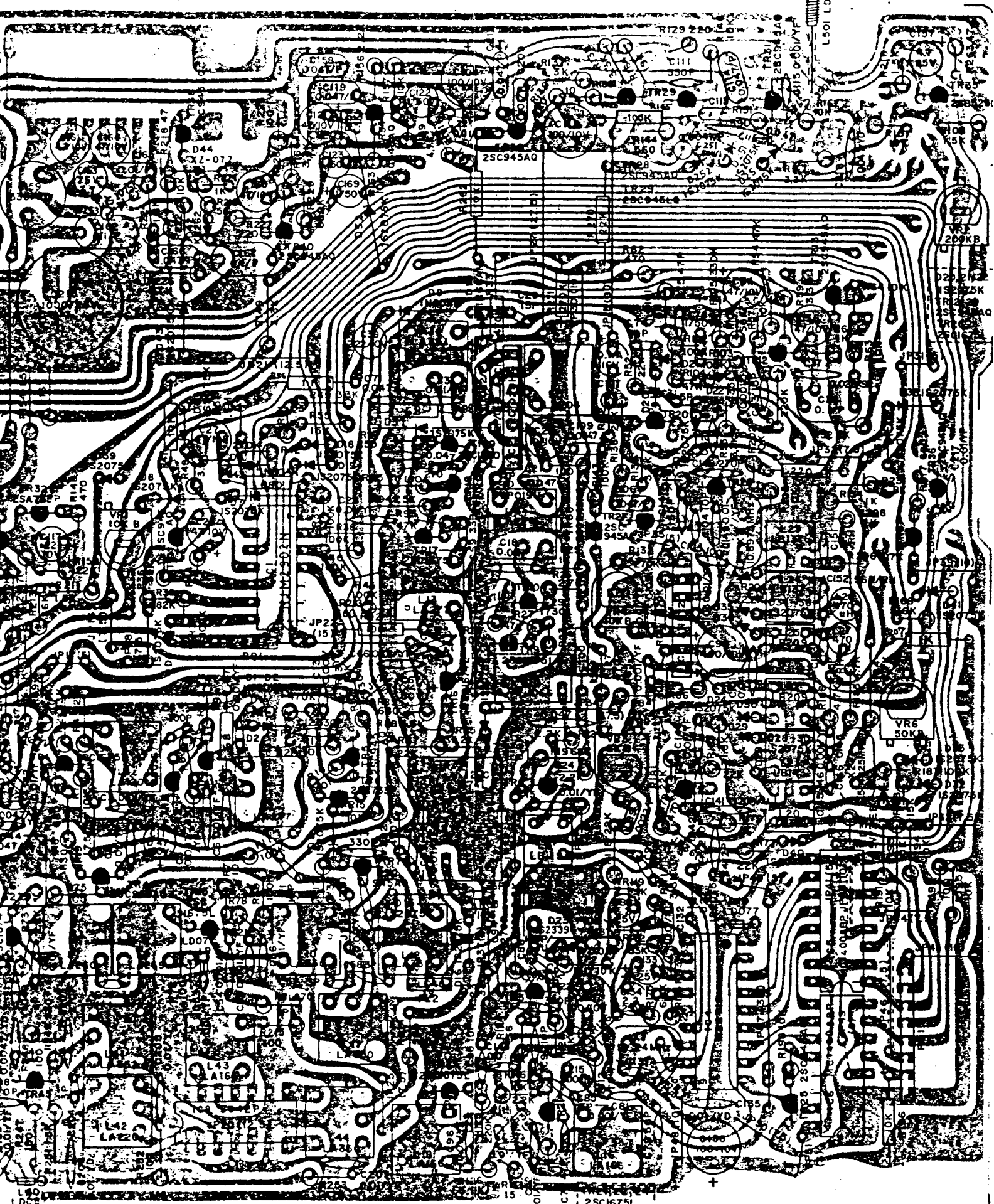

25C1675L

3C

3D

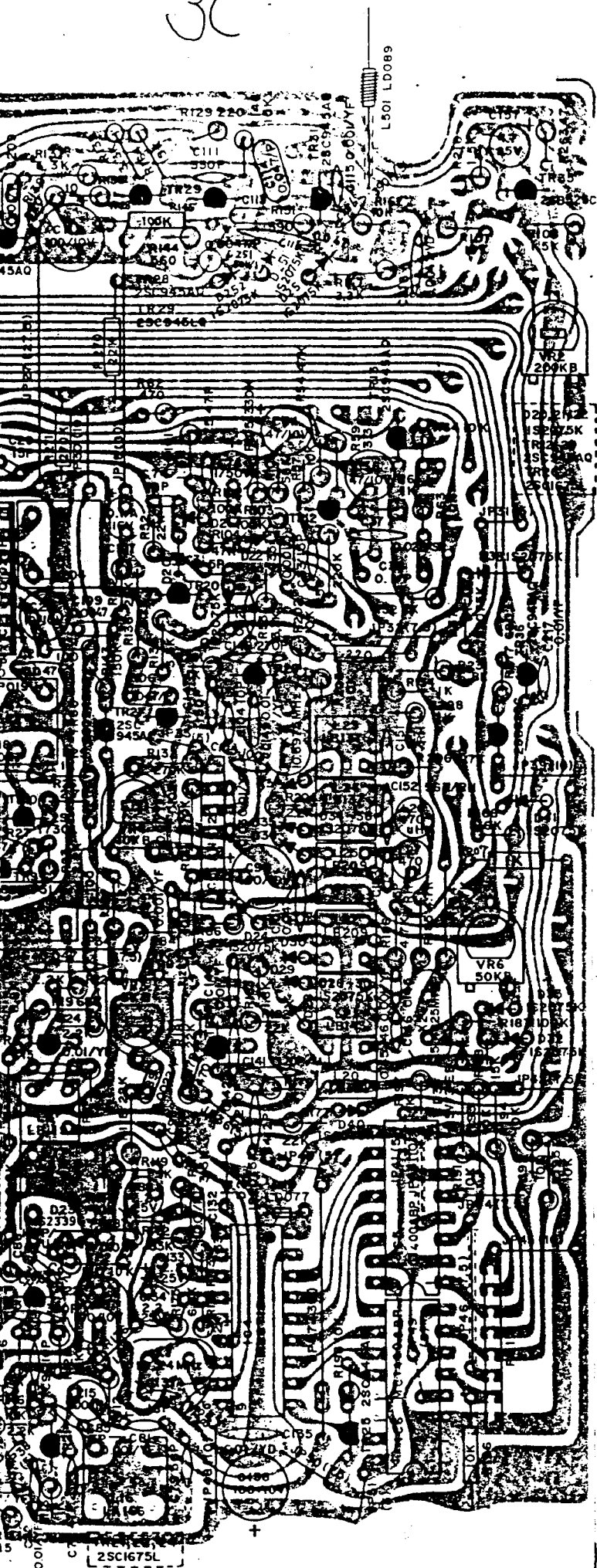

注)

1. 指示ナキ抵抗は全て V8 W デアル。
2. 指示ナキセラミックコンデンサノ温度特性ハ  
1000 PF 以下ハ SL, } デアル。  
1000 PF 以上ハ ZF }
3. 下記ノ部分をパラフィンロックサレ。

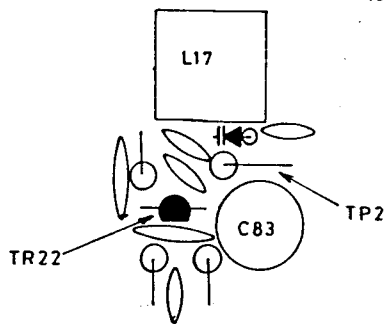

ORIGINAL

製品名	UT-539D1/2
基板	MAIN基板部取付図
番	E22-5287
校核	Kenmoto
日付	59.3.33



4A

4B

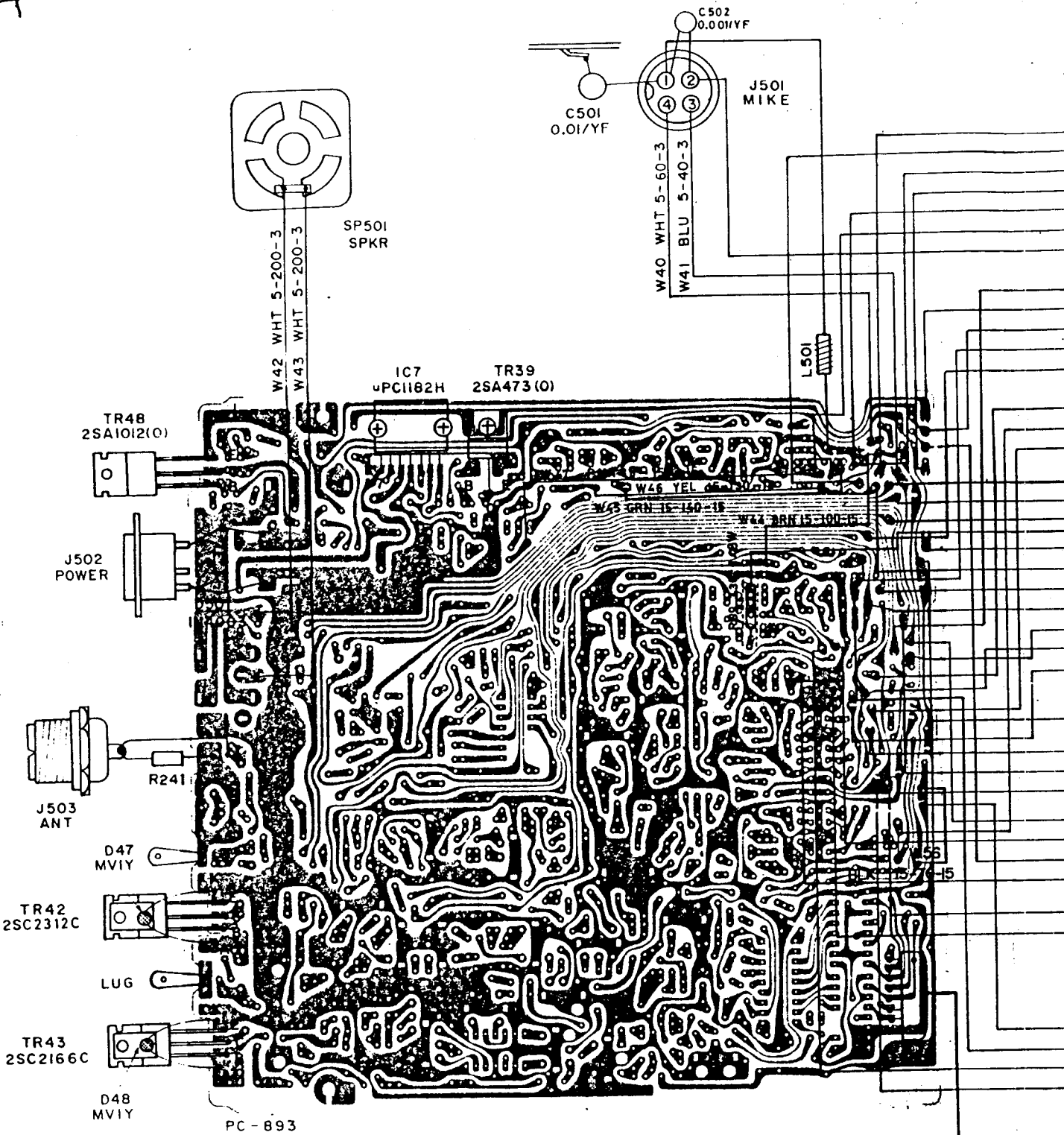

4B

4C

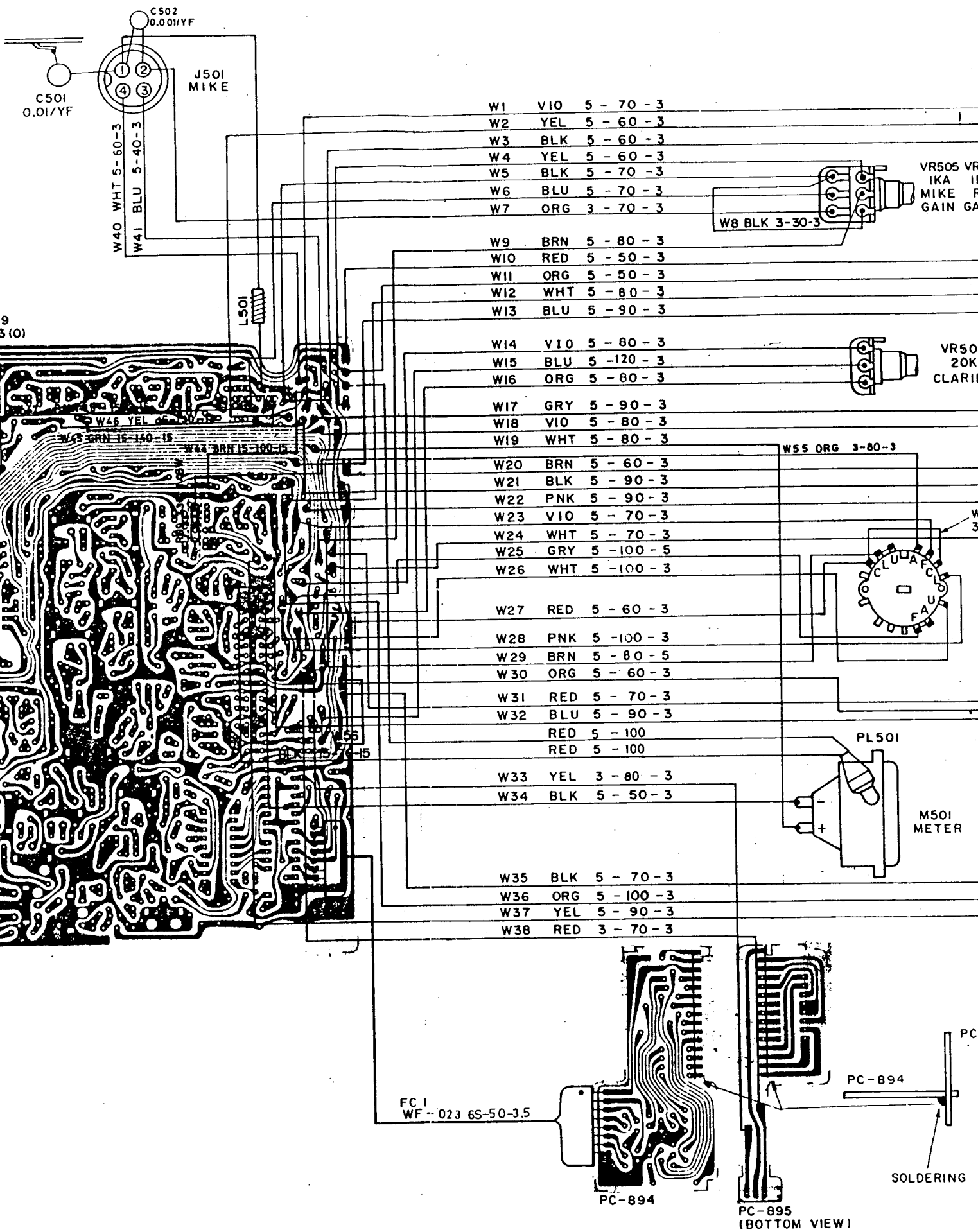

4C

4D

- W1 VIO 5 - 70 - 3
- W2 YEL 5 - 60 - 3
- W3 BLK 5 - 60 - 3
- W4 YEL 5 - 60 - 3
- W5 BLK 5 - 70 - 3
- W6 BLU 5 - 70 - 3
- W7 ORG 3 - 70 - 3
  
- W9 BRN 5 - 80 - 3
- W10 RED 5 - 50 - 3
- W11 ORG 5 - 50 - 3
- W12 WHT 5 - 80 - 3
- W13 BLU 5 - 90 - 3
  
- W14 VIO 5 - 80 - 3
- W15 BLU 5 - 120 - 3
- W16 ORG 5 - 80 - 3
  
- W17 GRY 5 - 90 - 3
- W18 VIO 5 - 80 - 3
- W19 WHT 5 - 80 - 3
  
- W20 BRN 5 - 60 - 3
- W21 BLK 5 - 90 - 3
- W22 PNK 5 - 90 - 3
- W23 VIO 5 - 70 - 3
- W24 WHT 5 - 70 - 3
- W25 GRY 5 - 100 - 5
- W26 WHT 5 - 100 - 3
  
- W27 RED 5 - 60 - 3
- W28 PNK 5 - 100 - 3
- W29 BRN 5 - 80 - 5
- W30 ORG 5 - 60 - 3
- W31 RED 5 - 70 - 3
- W32 BLU 5 - 90 - 3
- RED 5 - 100
- RED 5 - 100
  
- W33 YEL 3 - 80 - 3
- W34 BLK 5 - 50 - 3
  
- W35 BLK 5 - 70 - 3
- W36 ORG 5 - 100 - 3
- W37 YEL 5 - 90 - 3
- W38 RED 3 - 70 - 3

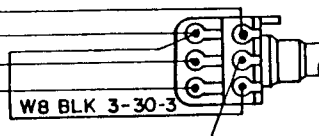

VR505 VR504  
IKA IKB  
MIKE RF  
GAIN GAIN

VR501 VR502  
50KA 50KB  
VOLUME SQUELCH

S501  
POWER

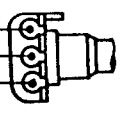

VR503  
20KB  
CLARIFIER

W55 ORG 3-80-3

W39 RED  
3-40-3

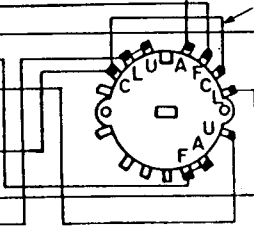

S502  
MOD

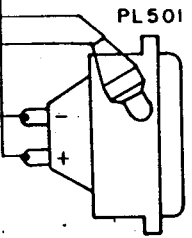

M501  
METER

S503  
PA ↔ CB

S504  
NB/ANL ↔ OFF

S509  
HI ↔ LOW

C503  
0.01/SR

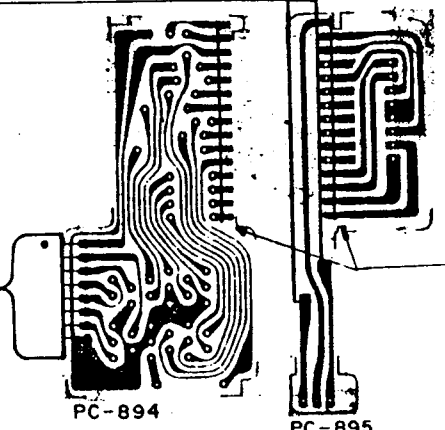

PC-894

PC-895  
(BOTTOM VIEW)

PC-894

PC-895

SOLDERING

ORIGINAL

機種名	UT-539D
材名	線材使用図
番	E32-2346
製造	製作
	Kumetsu IMAI
	59.3.23 S55.4.23

023 6S-50-3.5

## LISTE PIECES DETACHEES JACK

## LISTE PIECES DETACHEES JACK

CODE	DESIGNATION	QTE/MOD.	CODE	DESIGNATION	QTE/MOD.
BC002	BOBINE LD-077	2	BR092	BOBINE LB-143	1
BC003	BOBINE LD-087	5	BR093	BOBINE LB-144	1
BC004	BOBINE LE-096	2	DC001	DIODE 1N60 AM	5
BC005	BOBINE LE-151	1	DC004	DIODE XZ-072	1
BC007	BOBINE LE-187	1	DC005	DIODE 1S2075K	2
BC009	SELF LZ-016 100UH	1	DC007	DIODE MC-301	3
BC010	SELF LZ-016 470UH	2	DC008	DIODE 1N4003	1
BC013	BOBINE LD-033	1	DC009	DIODE MV-1YH	2
BC014	BOBINE LD-089	1	DV001	DIODE VARI-CAP 1S2688EB	1
BC017	BOBINE LC-072	1	DV002	DIODE 1S2339G	2
BR002	BOBINE LA-120	1	DV003	DIODE KB-262	1
BR003	BOBINE LA-165	1	HM001	MICROPHONE MK-221	1
BR004	BOBINE LA-166	3	HP002	HAUT-PARLEUR SP-057	1
BR005	BOBINE LA-220	1	IL001	CICUIT INTEGRE MC14008BCP	2
BR007	BOBINE LA-259	1	IP001	CIRCUIT INTEGRE UPC1182H	1
BR008	BOBINE LA-260	1	IR001	CIRCUIT INTEGRE AN612	1
BR010	BOBINE LA-350	3	IR002	CIRCUIT INTEGRE S042P	1
BR011	BOBINE LA-351	2	IR005	CIRCUIT INTEGRE NJM2902N	1
BR012	BOBINE LA-352	1	IR010	CIRCUIT INTEGRE UPC102BHA	1
BR014	BOBINE LB-119	1	IS001	CIRCUIT INTEGRE MB8719	1
BR015	BOBINE LB-137	2	JX001	JACK JK-089	2
BR016	BOBINE LB-209	2	JX002	JACK JK-052	1
BR047	BOBINE LB-276	1	JX003	JACK JK-068	1
BR048	BOBINE LB-277	2	JX005	JACK JK-087	1
BR050	BOBINE LB-279	1	DA001	AFFICHEUR UR-202D	1
BR055	BOBINE LA-204	1	PF001	FILTRE FL-048 SFE10.7MS2-M	1

CODE	DESIGNATION	QTE/MOD.
PF002	FILTRE FL-066	1
PF003	FILTRE G. FL-096	1
PQ001	QUARTZ 10.240	1
PQ002	QUARTZ 10.6975	1
PQ022	QUARTZ 15,4825	1
RV001	POTENTIOMETRE RV-222 20KB	1
RV004	POTENTIOMETRE RV-485 1KB.1KA	1
RV007	POTENTIOMETRE RV-329 50KB.50KA	1
SS001	COMMUTATEUR SR-208	1
SX002	COMMUTATEUR SR-187	1
SX037	COMMUTATEUR SW-178	1
TB001	TRANSISTOR 2SA473-0	1
TB003	TRANSISTOR 2SA1012-0	2
TH001	TRANSISTOR 2SC2166-C	1
TH002	TRANSISTOR 2SC2312-C	1
TX001	TRANSISTOR 2SA733-P	2
TX002	TRANSISTOR 2SC945A-Q	20
TX003	TRANSISTOR 2SC1674-L	3
TX004	TRANSISTOR 2SC1675-L	12
TX005	TRANSISTOR 2SC1730-L	4
TX006	TRANSISTOR 2SB525-C	3
TX010	TRANSISTOR 2SC2086-D	1
TX062	TRANSISTOR 2SC945L-Q	1
VM008	VU METRE MT-206	1
XX027	MANUEL DE MAINTENANCE JACK	1
XX100	MANUEL SCHEMAS UNIDEN - STABO	1

Pièces détachées Spécifiques à chaque Appareil			
EMETTEUR/RECEPTEUR	P.A. amplificateur de puissance.	P.L.L. boucle à verrouil- lage de phase	B.F. Basses Fréquences
JIMMY	2SC 2166	SM 5124	TDA 1905
JOHNNY	2SC 2166	SM 5124	TDA 1905
HARRY	2SC 2166	SM 5124	TDA 1905
TAYLOR	2SC 2029	TC 9106/SM 5126C	MB 3712
FRANCOIS	2SC 2029	TC 9109/SM 5126A	MB 3712
VALERY	2SC 2029	TC 9106/SM 5126C	MB 3712
WILSON	2SC 2166	SM 5124	UPC 1242
HERBERT	2SC 2166	TC 9106	UPC 1242
SS-120	2SC 1944	UPD 2816	TA 7222
JACK	2SC 2312	MB 8719	* UPC 1242
GRANT	2SC 2312	MB 8719	* UPC 1242
J.F.K.	2SC 1944	UPD 2816	MB 3712
SS-360	2SC 2312	MC 145106	TA 7222
JACKSON	MRF 477	MC 145106	* UPC 1242
LINCOLN	MRF 477	PLL 0305	TDA 1905
BENJAMIN	2SC 2312	D. 2824	UPC 1242
WILLIAM	2SC 2166	SM 5125	TDA 2822
MC 6700	2SC 1946	MB 8789	TA 7066 (combiné) MB 3713 (H.F.)

CONTACTER NOTRE S.A.V. concernant nos Conditions, Disponibilité et Tarif.

\* Ces appareils utilisaient sur les anciens modèles en B F : UPC 1182

PIECES DETACHEES

COMMUNES A PLUSIEURS APPAREILS

Ref. CIRCUIT BF	EMETTEUR/RECEPT .	Ref. P.A	EMETTEUR/RECEPTEUR
MB 3712	TAYLOR FRANCOIS VALERY J.F.K (2)	2SC 2166	JOHNNY  HERBERT WILSON HARRY
TDA 1905	HARRY-JIMMY PC-33 LINCOLN JOHNNY		WILLIAM  JIMMY
UPC 1242	GRANT JACKSON JACK HERBERT BENJAMIN	2SC 2029	PC-33X  TAYLOR FRANCOIS VALERY PC 33 /43
TDA 2822	WILLIAM		
TA 7222	SS-120 / ROBERT SS-360 / RICHARD RONALD FRANKLIN	2SC 1944	SS-120 J.F.K
TA 7066	MC-6700 (combiné)	2SC 2312	SS-360 GRANT JACK RONALD FRANKLIN BENJAMIN
MB 3713	MC-6700 ( H.P.)		
UPC 1182	JACK ancien GRANT modèle JACKSON	MRF 477	JACKSON LINCOLN
AFFICHEUR		MANUELS MAINTENANCE	TOUS MODELES
UR 202	VALERY SS-120 JFK SS-360 GRANT JACKSON JACK	LAMPES VU-METRE	

VU- METRE

COMMUTATEUR

POTENTIOMETRE

QUARTZ

Spécifique à chaque appareil

=====  
CONTACTER NOTRE S.A.V. concernant nos Conditions. Disponibilité et Tarif.  
=====

## PIECES DETACHEES

## COMMUNES A PLUSIEURS APPAREILS

Ref. P L L	EMETTEUR/RECEPT	Ref. HAUT-PARLEUR	EMETTEUR/RECEPT.
SM 5124	HARRY - JIMMY JOHNNY WILSON	SP 057/SP 227	VALERY TAYLOR FRANCOIS JACK PC 33X /43
TC 9106	TAYLOR PC-33/43/44 HERBERT	SP 053	SS-360 GRANT JACKSON
TC 9109	FRANCOIS VALERY	SP 052	JFK SS-120
UPD 2816	SS-120/ROBERT JFK	SP 154/SP 169	HARRY JIMMY JOHNNY WILSON
MB 8719	GRANT JACK		
MC 145106	SS-360/RICHARD JACKSON RONALD FRANKLIN	SP 149	HERBERT
PLL 0305	LINCOLN		
D 2824	BENJAMIN		
MB 8789	MC 6700		
SM 5125	WILLIAM		

CONTACTER NOTRE S.A.V. concernant nos Conditions, Disponibilité et Tarif



# PRESIDENT

ELECTRONICS EUROPE

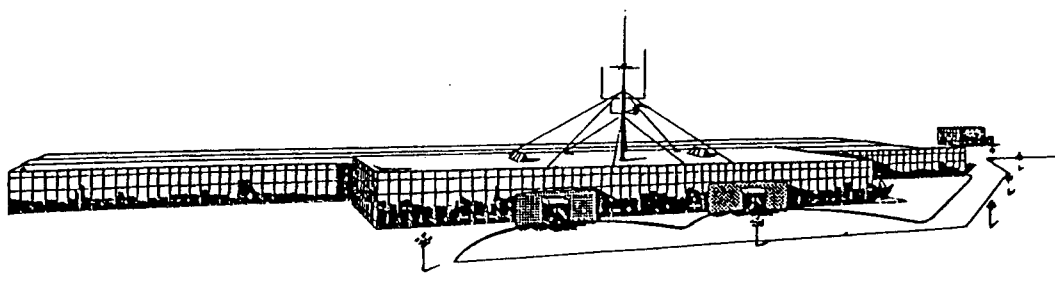

**SIEGE SOCIAL - FRANCE**  
Route de SETE - BP 100  
34540 BALARUC - Tél : 67.46.27.27  
Télex : 490534F - Fax : 67.48.48.49

**SUCCESSALE "ILE DE FRANCE"**  
50/56, rue du Pré des Aulnes  
Parc d'activités des Arpents  
77340 PONTAULT-COMBAULT  
Tél : (1) 60.29.28.27 - Fax : (1) 60.28.44.00



**VENTE EXCLUSIVE AUX DISTRIBUTEURS - 2 SUCCESSALES A VOTRE SERVICE**

S.A. CAPITAL 20.000.000 F.F. - SIREN SETE 315 230 490